



# WL400

## MANUAL



Waterlogic Commercial Products, LLC  
3175 Bass Pro Drive  
Grapevine, TX 76051  
(800) 288-1891 [www.waterlogicdealers.com](http://www.waterlogicdealers.com)  
Tech Portal Website: [techportal.waterlogic.com](http://techportal.waterlogic.com)

## **WL400 MANUAL**

Congratulations on your choice of the **Waterlogic WL400** water treatment system. The **WL400** model dispenses cold, and hot. Every **WL400** includes:



**High Performance Multi-Stage Filtration**



**Bio-Cote Anti-Microbial Protection**



**Firewall™ Advanced Purification**

The **Waterlogic WL400 Water Treatment System** provides exceptional quality and great tasting water with every use.

## **INTRODUCTION**

Carefully read and follow all instructions to ensure proper and efficient operation of your **W400 Water Treatment System**. Contact **Waterlogic** or an **Authorized Waterlogic Dealer** if you have any questions.

**Waterlogic** and **Authorized Waterlogic Dealers** employ trained service personnel who are experienced in the installation, function and repair of **Waterlogic** equipment. This publication is written for use by these qualified individuals. **Waterlogic** encourages users to learn about products, however, we believe that product knowledge and service is best obtained by consulting **Waterlogic** or an **Authorized Waterlogic Dealer**.

**Waterlogic Water Treatment Systems** should be combined with selected water treatment components to create a system specifically tailored for each application by trained and qualified personnel.

Products manufactured and marketed by **Waterlogic** and its affiliates are protected by patents issued or pending in the United States and other countries.

**Waterlogic** reserves the right to change the specifications referred to in this literature at any time, without prior notice. Changes or modifications not expressly approved by **Waterlogic** could void the warranty and user's authority to operate the equipment.

The **Waterlogic WL400** provides exceptional quality and great tasting water with every use.

## TABLE OF CONTENTS

### USER GUIDE

- Safety Alert Symbols .....4
- Safety Precautions.....4
- Features and Benefits .....6
- Certifications .....7
- Model Designations and General Specifications.....8
- Electrical and Shipping Specifications .....9
- Operating Instructions .....10
- Warranty .....12

### SERVICE GUIDE

- Service Requirements .....13
- Hot Tank Principles of Operation .....14
- Resetting the Hot Tank Overload (High Limit Safety) .....15
- Hot Tank Descaling.....16
- Increasing Faucet Flow.....18
- Display Panels and Icons .....19
- Disabling Sleep Mode.....20
- Programming.....21
- Opening Top Cover.....23
- Replacement Components (Consumables).....24
- Countertop Drawing and Parts List.....25
- Base Drawing and Parts List.....34
- Flow Diagram .....39
- Electrical Schematic .....40

### REVERSE OSMOSIS GUIDE

- RO Quick Guide Overview .....41
- Base Cabinet Side Removal .....42
- Base Cabinet Configuration.....43
- RO Setup and Filter Change .....44
- Inside Left Side Cabinet Configuration .....45
- Inside Right Side Cabinet Configuration .....46
- Replacing RO Membrane .....47

### INSTALLATION GUIDE

- Pre-Installation Procedures.....49
- Draining Procedure .....55
- Base Cabinet Assembly .....57
- Installation Instructions .....60

### TROUBLESHOOTING GUIDE

- Fault Codes.....63
- Power Troubleshooting.....65
- Dispense Troubleshooting.....68
- Cold Water Troubleshooting.....79
- Hot Water Troubleshooting .....80



## **SAFETY ALERT SYMBOLS**

Read and follow all safety information carefully. The signal words used in this manual are selected as shown below and based on an assessment of the degree of potential injury or damage (severe or minor) and the occurrence of injury (definitely occurs or has the potential to occur) when the warning is ignored:

**⚠ DANGER!**

*Indicates a situation which, when not avoided, results in death or severe injury.*

**⚠ WARNING!**

*Indicates a situation which, when not avoided, has the potential to result in death or severe injury; and/or severe property damage.*

**⚠ CAUTION!**

*Indicates a situation which, when not avoided, results or has the potential to result in minor injury; and/or minor property damage.*

## **SAFETY PRECAUTIONS**

### **Basic safety precautions should be followed, including the following:**

Ensure all local, state, and federal laws and codes including health and safety guidelines are met when installing **Waterlogic** Equipment. Only qualified service technicians should attempt installation and service of **Waterlogic** Equipment. Always read the entire operating instructions before using the appliance and save these instructions for future use.

**⚠ DANGER! ELECTRICAL SHOCK HAZARD.** *Always use a dedicated and properly grounded outlet. Unit should be protected by ground-fault circuit interrupter (GFCI) or residual current device (RCD) having a rated residual operating current not exceeding 30mA. Use only Waterlogic supplied power cord. Never use extension cords or power strips to connect unit. Do not use if the power supply cord is damaged. Always unplug from power supply prior to servicing.*

**⚠ WARNING! AUTHORIZED USE ONLY.** *This appliance is to be used for its intended purpose as described in this manual and untrained individuals who use this manual assume the risk of any resulting property damage or personal injury. This appliance can't be used by children and persons with reduced physical, sensory or mental capabilities or lack of experience.*

**⚠ WARNING! DO NOT OPERATE IF DAMAGED.** *Unplug if abnormal case occurs. Contact Waterlogic or authorized dealer for repair, service, and installation to avoid hazards.*

**⚠ WARNING! HOT WATER.** *Unit produces Hot Water in excess of 87°C (188°F). Water above 52°C (125°F) can cause severe burns or scalding. Keep unauthorized people and children away from the unit to avoid accidental dispensing of hot water.*

- ⚠ WARNING! CONNECT TO POTABLE WATER SUPPLY.** *This system is to be used for water only and is not intended for use where water is microbiologically unsafe or with water of unknown quality without adequate disinfection before or after the system.*
- ⚠ WARNING! TIP HAZARD.** *Dispenser could tip or fall causing serious injury. Always install unit on a firm, flat, and level surface and secure the **WL400 Water Treatment System** to the base cabinet with the screw provided to lock the components together. Secure unit to cabinet, wall, or floor if needed. Never place heavy items on top of unit and never climb, stand, or hang on unit or storage cabinet to prevent injury and damage.*
- ⚠ WARNING! UNIT IS HEAVY. TWO PERSON LIFT REQUIRED.** *Transport unit empty and always use material handling equipment or two people with proper lifting technique to reduce injury risk.*
- ⚠ WARNING! STORE AND TRANSPORT UNIT EMPTY. ALWAYS SANITIZE BEFORE USE.** *The unit must be completely drained and sealed before storing to avoid stagnation and reduce microbiological contamination (potential bacterial growth). Sanitize before use to eliminate any potential microbiological contaminants.*
- ⚠ CAUTION! INDOOR USE ONLY.** *Intended for household use only. Never expose to direct sunlight, heat sources, or ambient air temperature above 37°C (100°F) or below 2°C (35°F). Install indoors and keep unit away from excessive humidity. Never expose to freezing temperatures. Ensure there is adequate clearance around the unit to allow refrigeration system condenser to dissipate heat. Warmer environments require more clearance around the unit. Minimum clearance around all surfaces of the machine is 2-inches. Installs where the ambient temperature exceeds 27°C (80°F), require a minimum of 4-inches clearance for proper heat dissipation and efficient operation.*
- ⚠ CAUTION! USE A WATER PRESSURE REGULATOR.** *Waterlogic will not be responsible for injury or damage caused by excessive water pressure. Input or feed pressure must be 40 psi to 60 psi. Be aware of any potential pressure surges caused by building/municipal pumping stations.*
- ⚠ CAUTION! USE UV STABILIZED SUPPLY LINES.** *Feed the unit with a potable ambient or cold water supply only. Feed water over 37°C (100°F) can damage the treatment components. Water block devices and external leak detectors are strongly recommended. Locate the unit as close to the water supply and the electrical connections as possible. Locate the unit as close to the water supply and the electrical connections as possible. Immediately isolate or close water supply valve and contact service representative if leak is noticed.*

**Contact Waterlogic for assistance or help finding an Authorized Service Representative.**

## **WL400 FEATURES AND BENEFITS**

### **Ambient, Cold, Hot, and Extra Hot Water**

Pressure Fed Ambient, Cold, Hot, and Extra Hot Selections to meet a wide range of customer demands. Cold water temperature is adjustable.

### **High Volume Storage and Water Capacity**

The **WL400 Water Treatment System** has 4 liters (1 Gallon) of Cold Water Capacity and 1.2 Liters (.3 Gallons) of Hot Water Capacity.

### **Firewall™**

Firewall™ is proprietary technology that places the UV lamp at the point of dispense. This point of dispense purification keeps the dispense nozzle free from external contamination as well as purifying the water, making the freshest water possible.



### **BioCote® Anti-Microbial Protection**

Certain plastic, silicon, and painted surfaces surrounding the dispensing areas and drip tray are infused with an exclusive additive called BioCote®. BioCote® provides an effective barrier against microbes like bacteria and mold, which may cause odors or staining.



### **Large Dispense Area with Recessed Faucet**

9.5 inch dispense height with BioCote® recessed faucet to protect from cross-contamination.

### **Leak Detection**

**WL400 Water Treatment Systems** are supplied with a Sensor in the Leak Tray that halts water supply to prevent overflow and sounds alarm to reduce accident potential.

### **Energy Saving Sleep Mode**

Energy Saving Sleep Mode can be programmed to turn off heater after 3, 6 or 12 hours of inactivity and can be shut off.

## WL400 CERTIFICATIONS

*Waterlogic Water Treatment Systems* have been tested, approved, and certified by the world's top standards bodies such as NSF and ANSI. These organizations set and regulate national standards. We believe that performance testing and certifications validate *Waterlogic* as a world-leader in water treatment systems.

### WL400 Water Treatment System Certifications Include



#### UL399 – Certified Drinking Water Cooler

Intertek Labs (ETL) Certified the *WL400 Water Treatment System* to ANSI/UL 399 Standard for Drinking Water Coolers.

Intertek

#### CSA C22.2 No. 120 CSA Standard for Refrigeration



BPA Free - *Waterlogic* tests for BPA and declares that all of its products are Bisphenol-A FREE and contain no harmful BPA plastics.



#### NSF/ANSI-55 Class A –Ultraviolet Microbiological Water Treatment Systems

Water Quality Association is an international standards organization. Firewall™ Technology contains our latest, most innovative and patented breakthrough, “The Firewall™”, the most comprehensive UV purification system for point-of-use water treatment systems ever developed. The *Waterlogic Firewall™* components has been tested and certified by the Water Quality Association (WQA) to NSF/ANSI-55 Class A – Ultraviolet Microbiological Water Treatment Systems, and to NSF/P231 and the USEPA Standard for Microbiological Water Purifiers.

#### NSF P231 –Protocol for Microbiological Purifiers

The Public Health and Safety Organization establishes minimum requirements for health and sanitation characteristics of microbiological water purifiers. The requirements are based on the recommendations of the U.S. Environmental Protection Agency's Task Force Report.

#### NSF/ANSI-42 – Chlorine, Taste and Odor Reduction

#### NSF/ANSI-53 – Lead and Cyst Reduction

The Public Health and Safety Organization establishes minimum requirements for materials, design, construction, and performance of drinking water treatment units that are designed to reduce specific aesthetic-related contaminants in public or private water supplies.

#### Energy Star Certified

The *WL400 Water Treatment Systems*, have been tested and certified to the Energy Star, a US Environmental Protection Agency (EPA) program that helps our customers save money and protect our climate through superior energy efficiency.



*Waterlogic* is certified to ISO 9001:2015 – Quality Management Systems (certified by Intertek). ISO 9001 is the internationally accepted standard for well managed organizations that have adopted the key quality management principles to its operations to bring consistent quality products and a culture of continuous improvement.



### Safe Drinking Water Act

*Waterlogic* water treatment systems conform to the Safe Drinking Water Act (SWDA) “lead-free” amendment effective January 4, 2014.

## MODEL/PART DESIGNATIONS

BRAND NAME	DESCRIPTION	MODEL – PART NUMBER
<b>WL400</b> Counter Top	<i>Waterlogic WL400 Counter Top - Ambient, Cold, Hot and Extra Hot</i>	10-WL4FW-SB
	F-4FW-M-HCA-HC2P-SB-INN	
	Serial Number Prefix: 96	
<b>WL400</b> Base Cabinet	<i>Waterlogic WL400 Base Cabinet with RO</i>	10-WL4BC
	F-4FW-M-HCA-HC2P-SB-INN	

## SPECIFICATIONS

ITEM	
Water Connection	¼" Quick Connect
Cold Water Temperature	Cold Water Temperature – Factory Set Point 5°C (41°F) Adjustable from 3° - 12.2°C (37° - 54° F.)
Cold Tank Capacity	4 Liters (1 Gallon)
Hot Water Temperature	Hot Water Temperature – Factory Set Point 85°C (185°F) Adjustable from 70° - 95°C (158°F - 203°F)
Extra Water Temperature	Extra Hot Water Temperature – Factory Set Point 95°C (203° F)
Hot Tank Capacity	1.2 Liters (0.3 Gallons)
Hot Water Manual Reset Overloads	97°C (207° F)
Recommended Service Pressure	40-60 psi (275-414 kPa) – Use Pressure Regulator
Maximum Service Pressure	100 psi (689 kPa) – Use Pressure Regulator
Rated Service Flow	378.5 Liters per Day (Lpd) / 100 Gallons per Day (Gpd)
Environmental Temperature	1.67° - 38°C (35° - 100°F)
UV Lamp	13 Watts
Heater	500 Watts
Refrigerant Gas	R134a, 75g, 2.65 ounces
R134a Pressures	High (230 psi), Low (90 psi)



## SHIPPING SPECIFICATIONS

<u>ITEM</u>	<u>WL400 Counter Top</u>	<u>WL400 Base</u>	<u>WL400 Tower Combined</u>
Width/Depth/Height	42cm x 44.5cm x 44.5cm (16.5" x 17.5" x 17.5")	42 cm x 44.5cm x 80cm (16.5" x 17.5" x 31.5")	42 cm x 44.5cm x 125cm (16.5" x 17.5" x 49")
Weight (dry) of Box	26 kg (57 pounds)	28 kg (61 pounds)	53.5 kg (118 pounds)
Ship per Pallet	Up to 8 per pallet		4 per pallet in 2 boxes

\*WL400 Counter Top is 17.75 in. tall and may not fit between countertops and cabinets - Check installation to ensure adequate clearance.

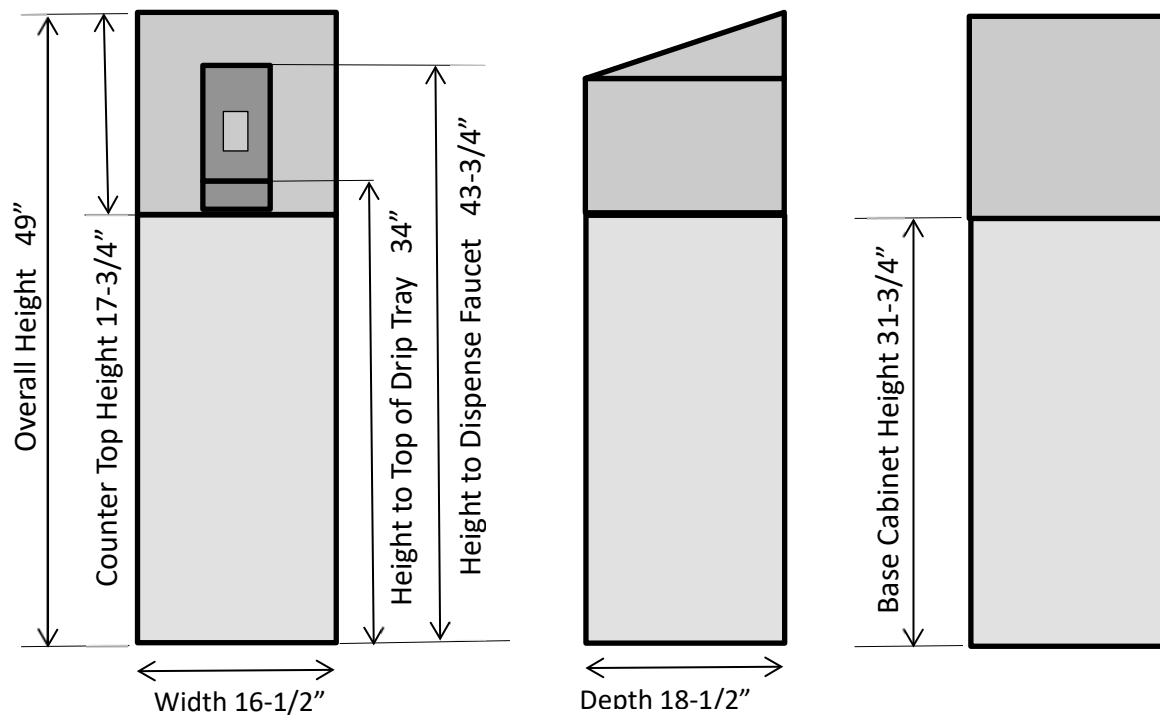



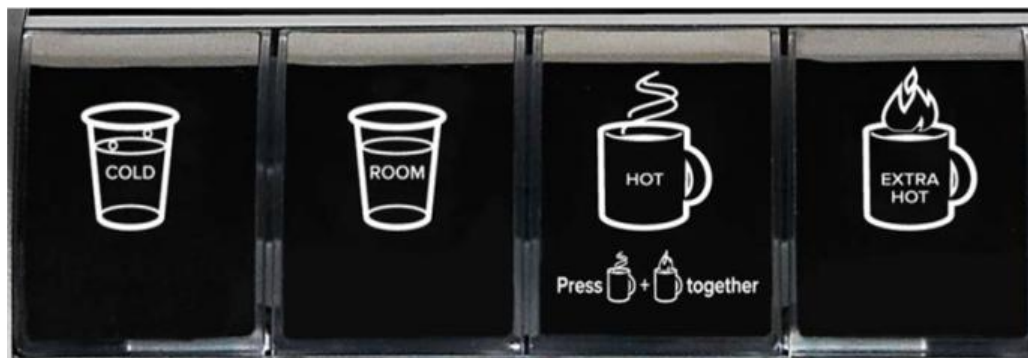

## ELECTRICAL SPECIFICATIONS

<u>ELECTRICAL SUPPLY</u>	<u>120V/60Hz</u>	<u>15 Amp Service<sup>+</sup></u>
<u>COMPONENT</u>	<u>POWER (approximate)</u>	<u>AMP DRAW (approximate)</u>
Heater	500	4.2 Amps
Compressor	114	1 Amp
Fan	16	0.1 Amps
Controls	15	0.1 Amps
UV Lamp System	13	0.1 Amps
Pump	12	0.1 Amps
<b>WL400 TOTAL</b>	<b>670</b>	<b>5.6 Amps</b>

## OPERATING INSTRUCTIONS



The above picture shows front dispensing panel for the *Waterlogic WL400 Water Treatment System*.

Button	Operational Use
	<b>COLD WATER:</b> Press the <u>Cold-Water</u> selection button. There may be a 2 second delay as Firewall™ UV lamp purifies the water and the Firewall™ Sensor ensures your safety. Blue light will illuminate the dispense area.
	<b>AMBIENT WATER:</b> Press the Room Temperature ( <u>Ambient</u> ) Water selection button. There may be a 2 second delay as Firewall™ UV lamp purifies the water and the Firewall™ Sensor ensures your safety. Green light will illuminate the dispense area.
	<b>HOT:</b> Press and hold both the <u>Hot Water</u> 185°F (85°C) and the Extra Hot Water selection buttons simultaneously for 2 seconds and hot water will dispense. This is a child safety feature. Red light will illuminate the dispense area.
	<p><b>EXTRA HOT:</b> Press the <u>Extra Hot Water</u> Selection button to elevate the hot tank to 203°F (95°C). Allow a few minutes for the temperature to rise in the hot tank.</p> <p>Press and hold both the Hot Water and the Extra Hot Water selection buttons simultaneously for 2 seconds and hot water will dispense. This is a child safety feature. Red light will illuminate the dispense area.</p> <p><b>⚠ WARNING!</b> <i>Unit produces Very Hot Water up to 203°F (95°C). Water above 125°F (52°C) can cause severe burns or scalding. Keep unauthorized people and children away from the unit to avoid accidental dispensing of hot water. Children should not use without supervision.</i></p>

Dispensing your choice of water is very simple.

1. Place your cup centrally in the dispensing area. Always use a cup suitable for use with hot water. Never hold cup or place hands in dispensing area while dispensing hot water. Never try to fill more than one cup at a time.
2. Select the type of water you wish to be dispensed by press/touching the Cold, Ambient or Hot water select icon until it illuminates.

 **WARNING!** *Unit produces Very Hot Water up to 95°C (203°F). Water above 52°C (125°F) can cause severe burns or scalding. Keep unauthorized people and children away from the unit to avoid accidental dispensing of hot water. Children should not use without supervision.*



## **WATERLOGIC MANUFACTURED WATER TREATMENT SYSTEM LIMITED WARRANTY** **UNITED STATES AND CANADA ONLY**

*Waterlogic water treatment systems are guaranteed to the original purchaser to be free of defects in materials and workmanship for a period of three (3) years from the date of purchase, but in no event longer than forty-eight (48) months from the date of manufacture. Waterlogic Commercial Products, LLC (“Waterlogic”) based in the U.S.A. and its affiliated companies are not liable for any cost of removal, installation, transportation, or any other charges which may arise in connection with a warranty claim.*

*This warranty does not cover damage or wear to products caused by abnormal operating conditions, accident, abuse, misuse, unauthorized or improper alteration or repair, damage caused by or resulting from shipping or accident, damage caused by hot water, freezing, flood, fire, or acts of God. The effects from chlorine corrosion, scaling and normal wear are specifically excluded from this warranty. This warranty does not cover products used outside the countries where the unit was purchased, and does not cover products that were not installed in accordance with Waterlogic printed installation and operating instructions obtained in training or from [www.waterlogic.us](http://www.waterlogic.us). Failure to follow all instructions for operation and maintenance voids the warranty. This warranty is not transferable.*

*To obtain warranty repairs or replacement, you must obtain a Return Authorization from Waterlogic. To obtain a Return Authorization, you must submit a Return Authorization form with supporting documentation to Waterlogic for evaluation. The form is available at [www.waterlogic.us](http://www.waterlogic.us). Supporting documentation must include, but is not limited to; proof of purchase, installation date, failure date, and supporting installation and maintenance data. After you submit a Return Authorization form and supporting documentation, Waterlogic will determine whether a reasonably apparent defect in materials or workmanship covered by this limited warranty exists. If Waterlogic determines the claimed defect is covered by this warranty, Waterlogic will, at its sole discretion, determine whether to correct the defect or replace the unit, free of charge to you. If Waterlogic determines that the unit should be returned for warranty service, Waterlogic will approve of return in writing and will issue a Return Authorization which you must obtain prior to shipping the product. You are responsible for the cost of freight in to Waterlogic.*

*Waterlogic and its affiliated companies hereby limit the duration of any and all implied warranties to a maximum period of three (3) years from the date of purchase including, but not limited to, the implied warranties of merchantability and fitness for a particular purpose. Some states do not allow limitations on how long an implied warranty lasts, so the above limitation may not apply to you. Consequential and incidental damages are not recoverable under this warranty. Some states do not allow the exclusion or limitation of incidental or consequential damages, so the above limitation or exclusion may not apply to you.*

*This warranty gives you specific legal rights and you may also have other rights which may vary from state to state.*

**New Warranty Policy issued by Waterlogic Commercial Products LLC, USA - January 10, 2014**

**Waterlogic Commercials Products LLC**  
3175 Bass Pro Drive  
Grapevine, TX 76051

**Tel:** (800) 288-1891  
**Website:** [waterlogic.us](http://waterlogic.us)

## SERVICE REQUIREMENTS

**⚠ WARNING!** *Read and understand the contents of this manual before attempting to service WL400. Failure to follow the instructions in this manual could result in death, serious personal injury, or severe property damage. Only trained and qualified technicians should attempt to install, maintain, or service Waterlogic Equipment.*

1. Visually inspect all electrical and water connections for signs of wear or damage.

**⚠ DANGER!** ***HIGH VOLTAGE ELECTRICAL HAZARD.** Unplug before inspection and service.*

2. **Waterlogic** recommends changing the UV Lamp Assembly and Wiring Harness must be replaced every 6 months.

13UV Lamp Assembly  
Part Number CT-2090-C WLCP Part Number 10-8075



**⚠ WARNING!** ***ULTRAVIOLET RADIATION.** Protect your skin and eyes against ultraviolet rays. Never look directly at an operating UV light. Disconnect before removing UV Lamp.*

**⚠ CAUTION!** ***UV LAMPS ARE HAZARDOUS.** Lamps are considered Hazardous Waste and must be disposed of accordingly. Refer to Product MSDS sheet for details.*

3. Clean the Quartz Sleeve that surrounds the UV lamp with a non-abrasive cloth, descaling solution, or ultrasonic bath if needed when changing UV Lamps.

**⚠ CAUTION!** ***UV SYSTEM IS FRAGILE.** Never handle the UV lamp or Quartz Sleeve with bare hands. UV Lamp and quartz sleeve must be free of oils and contaminants to ensure proper operation. Use a soft non-abrasive cloth to clean.*

4. Inspect the Quartz Sleeve O-ring for wear or damage and replace as necessary.
5. Ensure there is adequate (minimum of 2") clearance around the unit and clean the condenser grill and compressor fan to provide efficient cooling system operation.
6. Sanitize the Cold Tank per instructions in the Pre-Installation procedures.
7. Clean and sanitize external surfaces of the unit. Use soap and water or chemicals that are compatible with ABS plastic and will not damage or degrade the product surfaces.
8. Remove and clean the Faucet. Replace as needed.

**⚠ WARNING!** ***SANITIZER MAY CONTAIN HAZARDOUS CHEMICALS.** Use of proper personal protective equipment such as rubber gloves and eye protection is required.*

## HOT TANK PRINCIPLES OF OPERATION

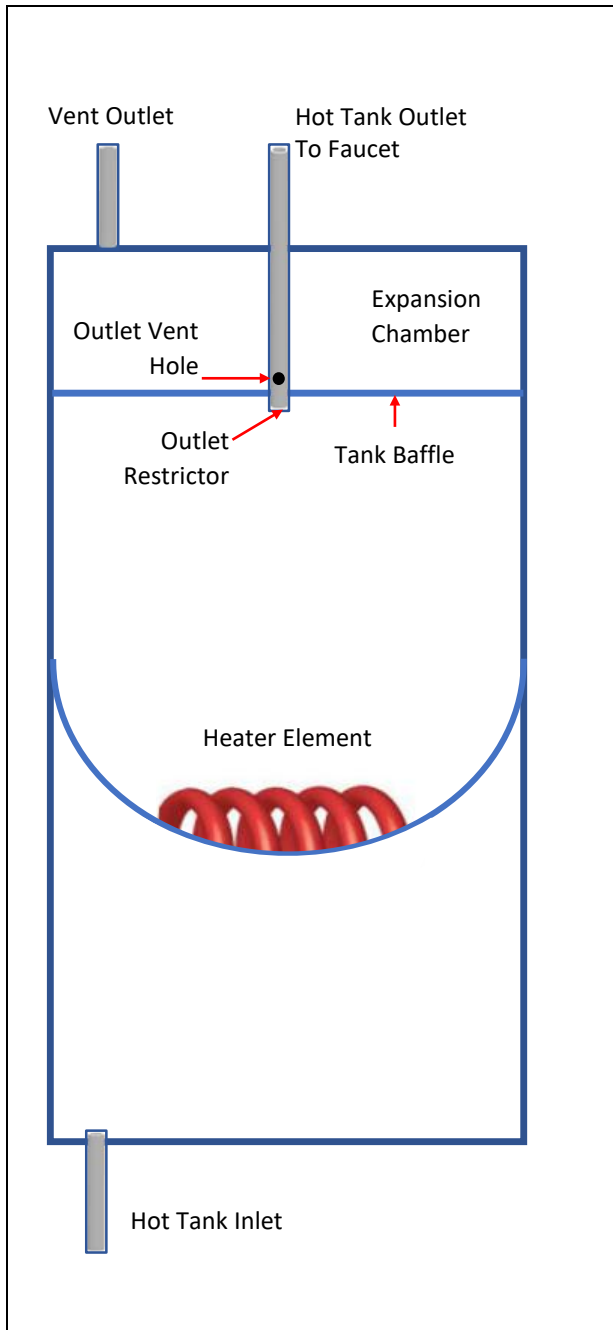

All **Waterlogic** Hot Tanks have a built in Vent or Expansion Chamber in the top of the tank except for WL270 (GF) units.

The Vent Chamber allows for expansion of the water when it is heated.

The chambers are separated by a welded-in tank baffle.

Water always flows into the bottom of the tank and out the top to the faucet.

The hot tank outlet tube has a restrictor in its base. This ensures the reservoir is always full by allowing more water in than out.

There is a small hole in the side of the tank outlet tube that allows air and water to pass into the vent chamber as it is heated.

Water in the vent chamber is suctioned back through the outlet tube vent hole when water is dispensed.





Expansion of water as it is heated in the reservoir will push the water out the faucet when the outlet tube vent hole becomes plugged with debris or scale.

The small Outlet Vent Hole is susceptible to scale build up and is a key indicator that descaling is required.

It is critical to descale the hot tank through the vent line and outlet line on a regular basis to prevent this problem.

Descaling through the inlet and/or outlet lines only will not clean the vent chamber and outlet vent hole properly.

## RESETTING THE HOT TANK OVERLOADS - HIGH LIMIT SAFETY

1.	Turn off Green Heater/Compressor Switch on rear of unit. <i>O=OFF</i>	
2.	Unplug the Power Cord from rear of unit.	
3.	Remove the Tower Cover Locking Screws and Slide Locks towards outside of unit to unlock both locks.	
4.	Slide Top Cover forward and lift in front of Top Cover to open.	
5.	Remove the 2 Phillips Screws from Left Side Panel (when standing behind unit) and remove side panel.	
6.	Check and press both Thermal Overload buttons on Hot Tank.	
7.	Close, lock and replace Top Cover Screws	
8.	Turn on Red Power Switch and Green Heater / Compressor Switch. <i>I=ON</i>	

## **HOT TANK DESCALING INSTRUCTIONS**

The hot tank requires removal of mineral deposits (descaling) on a regular basis. Typically descaling should take place every 6 to 12 months to preserve the long-term health of your unit.

Use non-toxic cleaner such as ScaleKleen, DEZCAL, 20% Citric Acid Solution, or Undiluted Vinegar Solution to remove mineral deposits as directed by the manufacturer depending upon filtration and local water conditions.

Descaling is an important process that removes calcium deposits, or scale, that can build up inside a tank over time. Calcium and scale is non-toxic but left unattended will hinder your unit's performance.

**⚠ WARNING!** ***PERSONAL PROTECTIVE EQUIPMENT REQUIRED.** Always ensure proper ventilation and use rubber or nitrile gloves and eye protection when using chemicals. Refer to Material Safety Data Sheet for specific requirements of each product.*

**⚠ CAUTION!** ***STAINLESS STEEL TANK DESCALING.***

*The hot tank is made from stainless steel. Ensure descaling solution is compatible with stainless and always flush the unit completely. Dispose in an environmentally safe manner.*

### **Materials Needed:**

- Personal Protective Equipment. Rubber or Nitrile Safety Gloves and Protective Eyewear
  - Phillips Screwdriver
  - Temperature Gauge
  - Water Pitcher or Container to collect water from the faucet
  - 5-gallon container or drain basin
  - Citric Acid Based Cleaner
  - ¼" Plastic Tubing, at least 4 feet in length, and assorted ¼" quick connect fittings
  - Sanitizing Cartridge
  - Food Coloring
1. Put descaler per directions and 3 drops of food coloring into the descaling cartridge.
  2. Connect descaling cartridge to the inlet water supply and connect to inlet bulkhead fitting on the back of the unit. Turn on Water Supply.
  3. Select Hot Water and depress the Main Dispensing Button on the Front Control Panel until descaling solution (colored water) comes out of the faucet. Container and drain basin will be required to catch water from the faucet.
  4. Turn off water supply and remove sanitizing cartridge from inlet water supply. Reconnect water supply to inlet fitting.



5. Allow descaling solution to remain in the Hot Tank for 15 minutes (length of time may vary depending on water conditions).
6. Place a pitcher, catch basin or other container under the faucet of the **WL400 Water Treatment System**.
7. Flush the Hot Tank until water runs clear.
8. Once clear water dispenses from the faucet the Hot Tank has been descaled. Always ensure unit is performing to the customer's satisfaction.

**⚠ WARNING! HOT WATER HAZARD.** *WL400 Water Treatment System produces VERY HOT WATER up to 95°C (203°F). Water above 52°C (125°F) can cause severe burns or scalding. Hot water should be dispensed carefully into insulated container to avoid injury.*

**⚠ CAUTION! MUST REPLACE HOT TANK 3-5 YEARS DEPENDING ON USAGE.** *The hot tank and its controls must be replaced a minimum of every five years to ensure efficient and dependable operation.*

**⚠ WARNING! REINSTALL ALL PANELS AND COVERS.** *Always reinstall all panels, protective covers, and fasteners after servicing equipment. Failure to do so could result in severe personal injury and will void the certifications and warranty of the equipment.*

## INCREASING FAUCET FLOW

To increase flow from the WL400, you may turn up the RO pressure switch to 60 psi by removing the right lower panel of the base cabinet to access the switch. Turn adjusting screw in (clock wise) 6 turns or until output pressure is 60 psi, verify with pressure gauge.

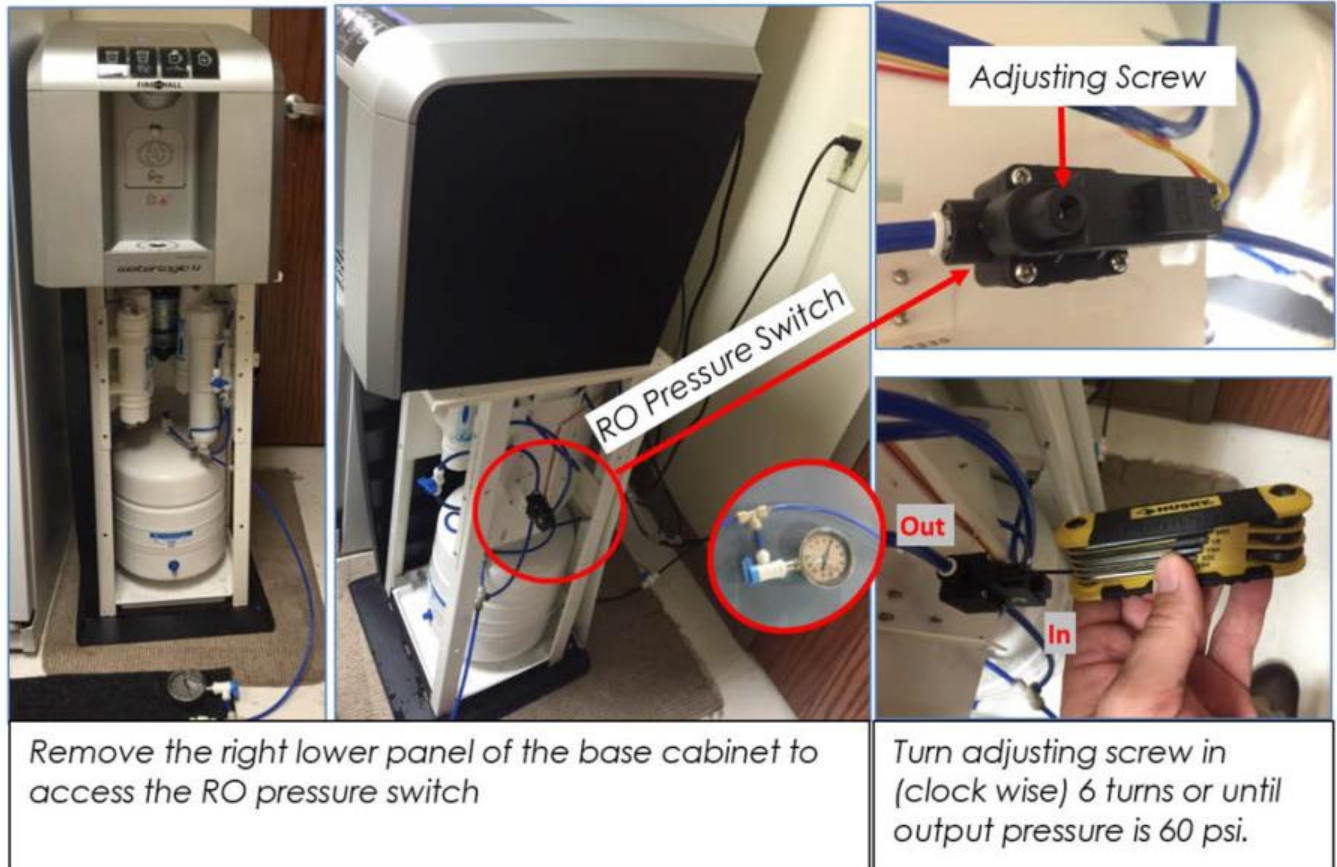

## DISPLAY PANELS AND ICONS



UV Lamp Has Failed  
*See troubleshooting section of manual*



The UV Lamp is operating



Sleep Mode -  
press any button to bring machine out of sleep mode



The Hot Tank is heating up



A leak has been detected - *See troubleshooting section of manual*



Filter needs replacing



The Cold Tank is Chilling



Extra hot water has been selected



The Drip Tray is Full – Please empty the tray

## DISABLING SLEEP MODE



Sleep Mode - press any button to bring machine out of Sleep Mode.

## PROGRAMMING INSTRUCTIONS

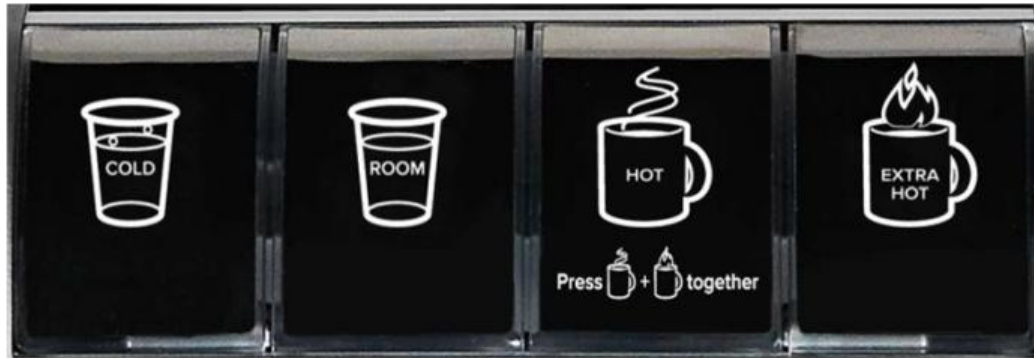

The above picture shows front dispensing panel for the *Waterlogic WL400*.

Press and Hold all 4 dispensing buttons for 10 seconds.

There are 5 options in the menu.

Cold Button cycles down the menu

Room (Ambient) Button cycles up the menu

Hot Button Selects the Option

Extra Hot Button Exits the menu

Settings	Programming
F-S Filter Setting	Filter Setting can be adjusted between 1,000 to 9,000 gallons in 1,000 increments.
F-r Filter Resetting	Choices are Yes or No
C-S Cold Temperature Setting	Temperature Setting can be adjusted from 2.8°C to 12.2°C (37°F to 54°F)
H-S Hot Temperature Setting	Temperature Setting can be adjusted from 70°C to 95°C (158°F to 203°F)
S-S Sleep Mode	Choices are 3 Hour, 6 Hour, 12 Hour or No (Off)

## PROGRAMMING INSTRUCTIONS

### Reset the Display Counter (Gallons)

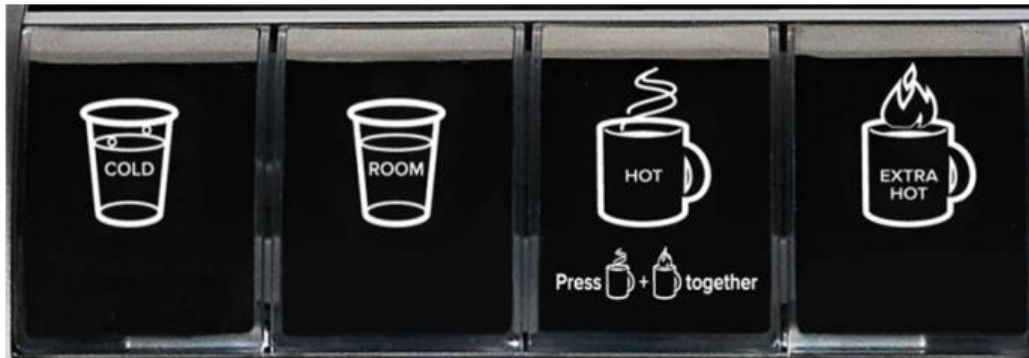

Reset Gallons Counter on the Display to “0000”

1. Press and Hold all 4 dispensing buttons for 10 seconds.
2. Release when programming mode is initiated and **F-s** is shown on screen
3. Press Cold to scroll down to the **F-r** (Filter Reset Menu)
4. Select **Hot button** to enter into the Filter Reset Menu Options
5. Scroll down to “Yes” by using the **Cold and Ambient Buttons** (up and down)
6. Select **Hot** to enter (Yes to Filter Reset)
7. Select **Extra Hot** to Exit and the Gallon Counter will be reset and will display 0000.

## OPENING TOP COVER

1. Remove screws from slide locks located near dispenser.
2. Push Slide Locks inward toward dispensing area.



3. Pull Cover forward and lift from the front to open Top Cover.

4. Locate Top Cover Support Arm attached to left side panel.
5. Lift Support Arm from the front and align with top cover to hold top cover in place.

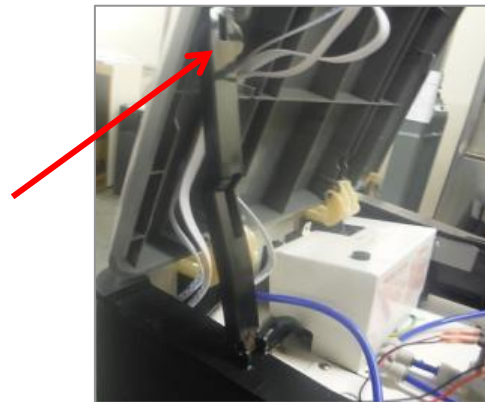

## REPLACEMENT COMPONENTS - CONSUMABLES

Component	WLCP PN	Frequency of Replacement
UV Light, 13 Watts	10-8075	Every 6 months, or as required Part No CT-2090-A
Spiral	10-8080	Clean every 12 months, replace as needed Part No -0007-A
Hot Tank 185°F (85°C)	HT-3037-A	Replace every 3-5 years depending on usage Part No HT-3037-A
Sediment Filter	10-8050	Every 6-months, or as required. Local water conditions will determine proper filter type and maintenance schedule. Part No. RO-0001-A
Pre-Carbon Filter	10-8055	Every 6-months, or as required. Local water conditions will determine proper filter type and maintenance schedule. Part No. RO-0002-A
RO Membrane Replacement Kit 75 GPD	10-8061	Every 6-months, or as required. Local water conditions will determine proper filter type and maintenance schedule.
Post Carbon Filter	10-8065	Every 6-months, or as required. Local water conditions will determine proper filter type and maintenance schedule. Part No. RO-0005-A

*\* One pre-installed. One required for NSF-53 and NSF P231 Certification.*

**Replacement parts can be obtained from *Waterlogic* or an *Authorized Waterlogic Dealer*. See *Parts Layouts, Drawings, and Lists* for additional repair parts.**

### Hot Tank Service

Hot Tanks (with controls) must be replaced at least every 3-5 years depending on usage. Descaling hot tank may be required on a regular basis depending upon filtration and local water conditions. See Service Section.

### NOTE:

At the **end of this product's life**, ensure that it is disposed of in an environmentally friendly manner which is fully compliant **with all Federal/State/Local Requirements and Guidelines**.



## WL400 COUNTER TOP MAIN PARTS DRAWING AND PARTS LIST

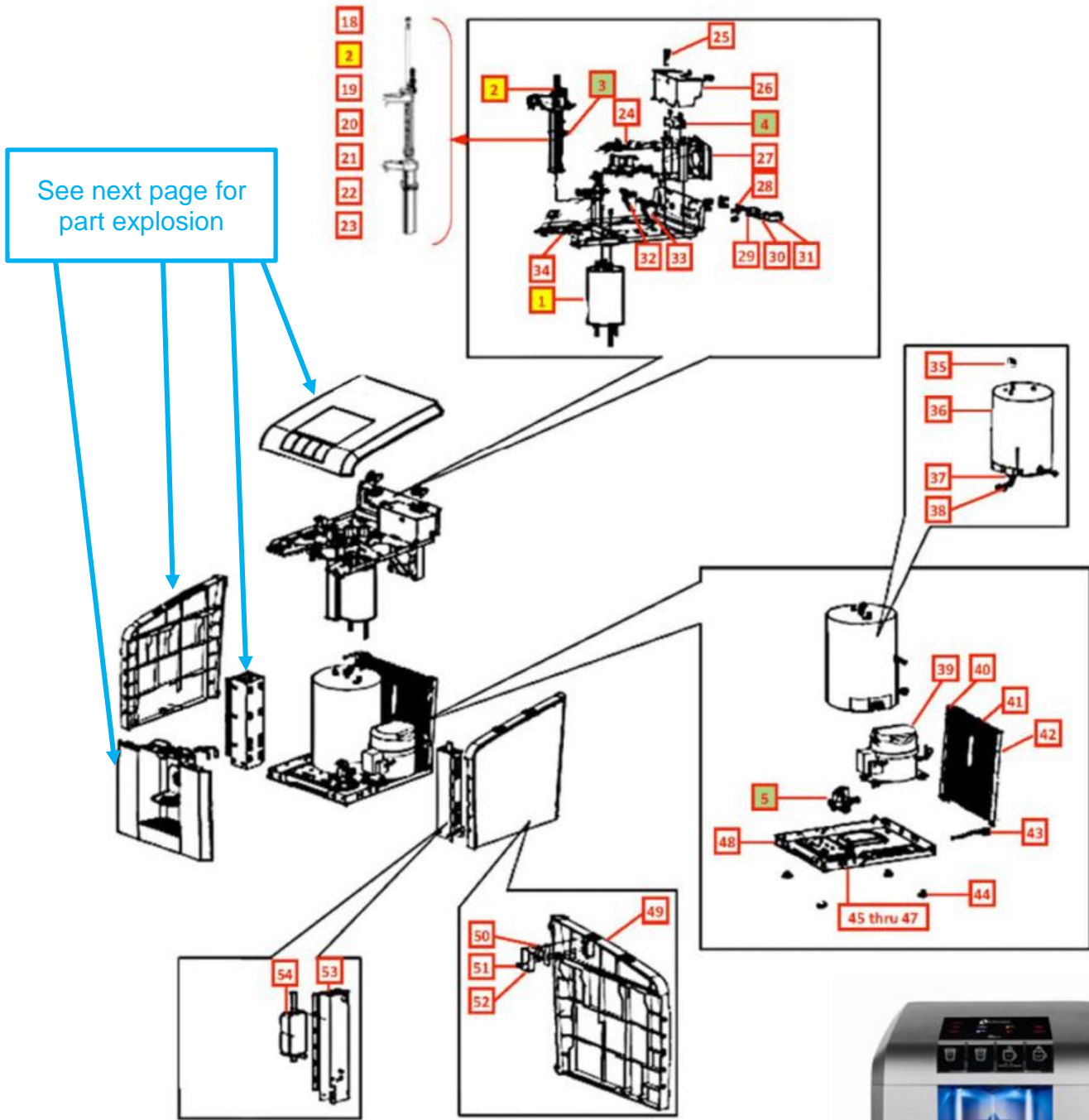



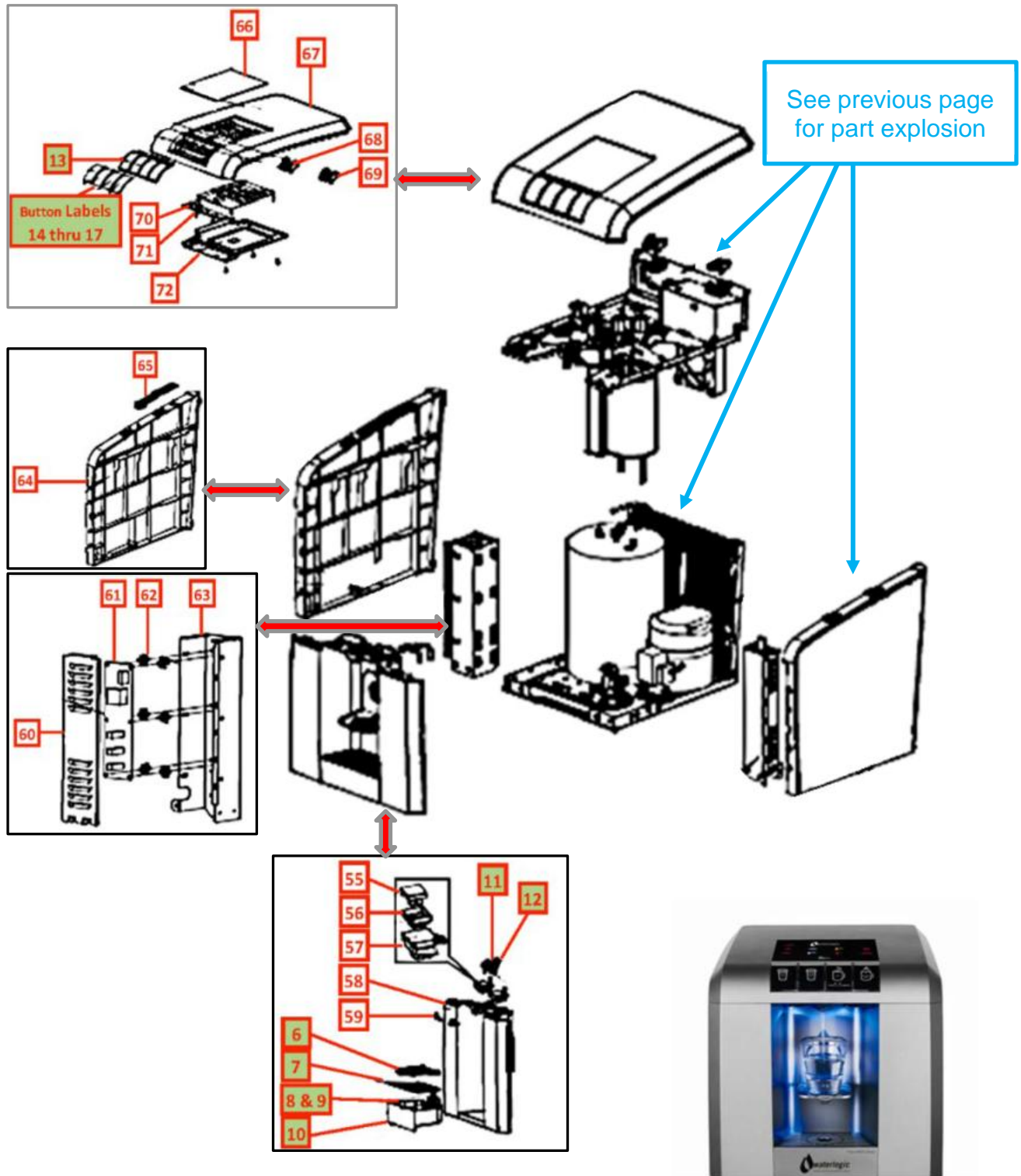





## WL400 COUNTER TOP MAIN PARTS DRAWING AND PARTS LIST



## WL400 COUNTER TOP MAIN PARTS DRAWING AND PARTS LIST

No	WLCP Part No.	Description	Part No.	Stocked?	
<b>Consumables</b>					
1	HT-3037-A	1.2L 120V 500W Steel Hot Tank	HT-3037-A	Yes	
2	10-8075	13W UV Lamp Assembly	CT-2090-C	Yes	
Not Shown	10-8061	75 GPD - RO Membrane Kit - Includes: 15-3001 RO Membrane, 15-3020 RO Membrane Housing, 2 each JG 480821S Fittings, and RO Membrane Instructions.	NA	Yes	
Not Shown	15-3001	RO Membrane	NA	Yes	
Not Shown	15-3020	RO Membrane Housing	NA	Yes	
Not Shown	10-8050	RO Sediment Filter	RO-0001-A	Yes	
Not Shown	10-8055	RO Pre-Carbon Filter	RO-0002-A	Yes	
Not Shown	10-8065	RO Post Carbon Filter	RO-0005-A	Yes	
Not Shown	01-2076	Scale Kleen	NA	Yes	
<b>Recommended Spare Parts</b>					
3	AK-0064	UVC Sensor	AK-0064	Yes	
4	NA	Ballast	EL-0010-L00-00	No	
5	PU-4016-C	Solenoid Valve DC24V FS Bitron	PU-4016-C	Yes	

5.1	CU-0001	Solenoid Cushion	CU-0001	Yes	
6	PL-1344-A	Adjustable Cup Tray	PL-1344-A	Yes	
7	PL-1320-A	Drip Tray Grill - Silver	PL-1320-A	Yes	
8	ST-8267-C	Drip Tray Sensor Pin - Left	ST-8267-C	Yes	
9	ST-8267-D	Drip Tray Sensor Pin - Right	ST-8267-D	Yes	
10	PL-1319-F	Drip Tray Body – Silver	PL-1319-F	Yes	
11	PL-1354	Firewall Hot Water Faucet	PL-1354	Yes	
12	PL-1354-A	Firewall Hot Water Faucet Insert Pipe	PL-1354-A	Yes	
13	PL-1323	Button Panel	PL-1323	Yes	
14	LP-7310	Cold Button Label	LP-7310	Yes	
15	LP-7311	Ambient Button Label	LP-7311	Yes	





16	LP-7312	Hot Button Label	LP-7312	Yes	
17	LP-7313	Extra Hot Button Label	LP-7313	Yes	
<b>Remaining Parts</b>					
18	10-8085	UV Lamp Fixing Rubber (Silicon)	CT-2001-B	Yes	
19	10-3095	CDS Fixing Rubber (Silicon)	CT-2010	Yes	
20	10-8095	Firewall UV Lamp Fixing Rubber	CT-2078-A	Yes	
21	10-8090	Spiral Quartz Spacer	CT-2077-A	Yes	
22	10-8080	Quartz Spiral for Firewall	FU-0007-A	Yes	
23	FU-0009-A	Firewall Assembly	FU-0009-A	Yes	
24	ST-8300	Firewall Fixing Bracket	ST-8300	Yes	
25	10-3014	Fuse Holder and Fuse 120V / 15A with One Wire	EL-5053	Yes	
26	ST-8283	Electronics Cover Bracket	ST-8283	Yes	
27	10-1500	Fan Motor 110V (AC Axial fan)	CT-2011	Yes	

27.1	NA	Fan Bracket	ST-8265	No	
28	10-3067	Bulkhead Union 1/4" x 1/4" John Guest P/N PI1208S	PU-4028	Yes	
29	10-4013	Socket with ElectroMagnetic Interference Filter (EMI)	EL-5016	Yes	
30	10-3008	Red Compressor and Heater Switch	EL-5004	Yes	
31	10-3009	Green Power Switch	EL-5005	Yes	
32	PL-1330	Back Panel Hinge (A-4)	PL-1330	Yes	
33	PL-1331	Back Panel Hinge (A-1)	PL-1331	Yes	
34	NA	Upper Shelf / Back Panel	ST-8259-H	No	
34.1	PL-1336	Upper Panel Wire Route Hole Silicon Cover	PL-1336	Yes	
35	Purchase from John Guest	JG Equal Elbow Connector 1/4" (PI0308S)	PU-4008	Purchase from John Guest	
36	NA	Cold Tank	CT-2072-A	No	
37	PU-4140	JG End Stop 1/4" (PI4608S)	PU-4140	No	
38	PU-4011-A	JG Equal Tee Connector 1/4" (PI0208S)	PU-4011-A	No	
39	10-2200	Compressor (R134a 1/8HP) 110V/60Hz	CO-9001-A	Yes	
39.1	10-3003	Compressor Starter Relay	CO-9016	Yes	

39.2	10-5018	Compressor Overload (LG Compressor)	CO-9015	Yes	
40	NA	Mini Front Support Frame - Left	ST-8255	No	
41	NA	Wire Condenser	CO-9041		
41.1	12-1001	Filter Dryer	CO-9008	Yes	
42	NA	Mini Front Support Frame - Right	ST-8256	No	
43	14-5011	Drain Valve & Cap 5/16"	CT-2028 and CT-2031-A	Yes	
44	12-3150	Unit Rubber Feet	PL-1251-CN	Yes	
45	PL-1375	Leak Containment Tray	PL-1375	Yes	
46	PL-1311	Leak Detection Sensor Bracket	PL-1311	Yes	
47	12-3180	Leak Containment Tray Clip (sensor 0.5mm)	ST-8207-CN	Yes	
48	NA	Mini Bottom Shelf	ST-8258	No	
49	PL-1327	Mini Side Panel - Right	PL-1327	Yes	
50	ST-8286	Micro Switch Metal Cover	ST-8286	Yes	
51	PL-1329	Safety Micro Switch Cover	PL-1329	Yes	
52	14-5006	Micro Door Lock S/W only	EL-5027	No	
53	NA	Adaptor Holding Bracket	ST-8261	No	

54	EL-5128	Power Adaptor with Fixing Bracket	EL-5128	Yes	
55	EN-6119	LED PCB	EN-6119	Yes	
56	PL-1335	LED PCB Holder Sealing Rubber	PL-1335	Yes	
57	NA	LED Holding Plate	PL-1318	No	
58	PL-1312-C	Front Upper Panel - Silver	PL-1312-C	Yes	
59	PL-1317	Top Cover Lock with screw hole	PL-1317	Yes	
60	NA	Main PCB Metal Cover	ST-8285	No	
61	EN-6137	Main PCB	EN-6137	Yes	
62	10-3017	Plastic PCB Support	EN-6059	Yes	
63	NA	PCB Holder Bracket	ST-8260	No	
64	PL-1321	Top Cover Safety Support	PL-1321	Yes	
65	PL-1328	Mini Side Panel - Left	PL-1328	Yes	
66	PL-1337-E	LCD Cover Panel (Word Printed for Each Icon)	PL-1337-E	Yes	
67	PL-1322-C	Silver Top Cover with Firewall Logo	PL-1322-C	Yes	
68	PL-1332	Back Panel Hinge (A-2)	PL-1332	Yes	
69	PL-1333	Back Panel Hinge (A-3)	PL-1333	Yes	
70	EN-6118	Dispense PCB	EN-6118	Yes	



71	EN-6136	Display PCB	EN-6136	Yes	
72	PL-1334	PCB Cover	PL-1334	Yes	
Not shown	PU-4031	JG LLD PE Tube - Blue O.D.1/4"John Guest P/N PE-08-BI-1000F-B	PU-4031	No	
Not shown	10-7040	Silicon Tube 5/16" for hot water	PU-4064	Yes	
Not Shown	10-3007	Power Cord 120V – 1825 mm	EL-5001-B	Yes	

## WL400 BASE MAIN PARTS DRAWING AND PARTS LIST

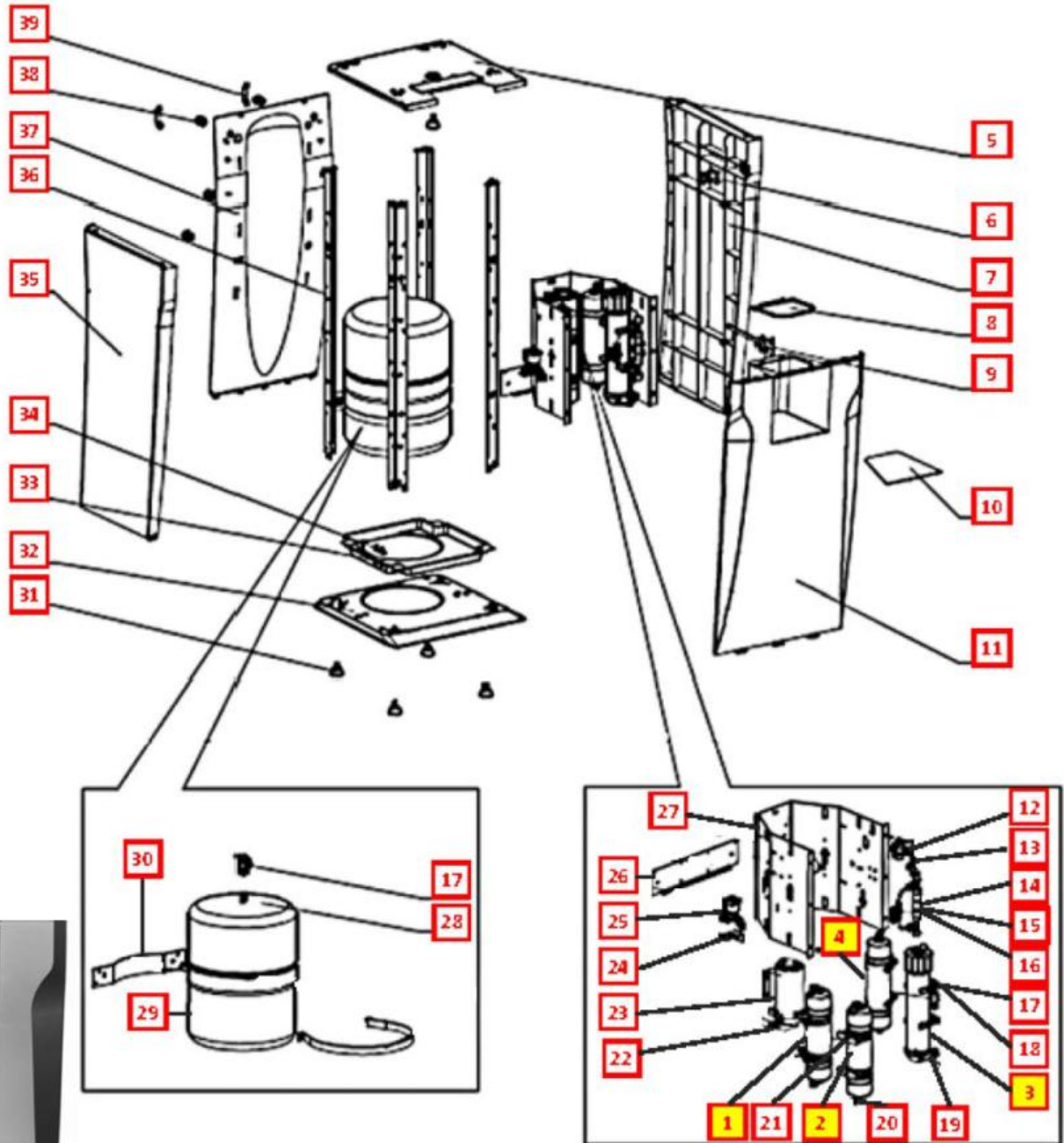



## WL400 BASE LAYOUT DRAWING AND PARTS LIST

No	WLCP Part No.	Description	Part No.	Stocked?	
<b>Consumables</b>					
1	10-8055	RO Carbon Filter (PRE-FILTER)	RO-0002-A	Yes	
2	10-8050	RO Sediment Filter	RO-0001-A	Yes	
3	15-3001	75 GPD RO Membrane	NA	Yes	
3	10-8061	<i>75 GPD RO Membrane Kit - Includes: 15-3001 RO Membrane, 15-3020 RO Membrane Housing, 2 each JG480821S Fittings, and RO Membrane Instructions.</i>	NA	Yes	
4	10-8065	RO Carbon Block Filter (POST FILTER)	RO-0005-A	Yes	
<b>Remaining Parts</b>					
5	NA	Base Cabinet Upper Shelf	ST-8268	No	
6	PL-1342	Base Cabinet Door Lock Cover	PL-1342	Yes	
7	PL-1340	Base Cabinet Plastic Side Panel - Right	PL-1340	Yes	
8	PL-1343	Base Cabinet Cup Dispenser Cover	PL-1343	Yes	
9	ST-8272	Base Cabinet Door Lock Bracket	ST-8272	Yes	
10	ST-8336	Cup Dispenser Hole Metal Cover	ST-8336	Yes	
11	PL-1341-A	Base Cabinet Front Bottom Panel - Silver	PL-1341-A	Yes	
12	RO-0024	High Water pressure switch	RO-0024	Yes	
13	Purchase from John Guest	JG Equal Tee Connector 1/4" (PI0208S)	PU-4011	No	

14	RO-0011	Flow Restrictor Micro	RO-0011	Yes	
15	RO-0010-A	Flushing-Valve Micro	RO-0010-A	Yes	
16	RO-0009-A	T-connect (2) Micro	RO-0009-A	Yes	
17	12-6102	JG Shut Off Valve NPT 1/4" (PPSV500822W) 5/16" * 1/4"	PU-4082	Yes	
18	RO-0006-A	1/4" Rigid Elbow for RO Housing - Micro	RO-0006-A	Yes	
19	15-3020	RO Housing	NA	Yes	
20	Purchase from John Guest	JG Equal Elbow Connector 1/4" (PI0308S)	PU-4008	No	
21	10-3099	2 1/2" Filter Clip	PU-4024	Yes	
22	Purchase from John Guest	JG Equal Straight Connector 1/4"(PI0408S)	PU-4010	No	
23	10-7235	Water Pressure Pump	CT-2035-E	Yes	
24	ST-8298-A	Firewall Fixing Bracket	ST-8298-A	Yes	
25	PU-4017-B	Solenoid Valve DC24V 300mm	PU-4017-B	Yes	
26	ST-8334	RO Filter Bracket Support	ST-8334	Yes	

27	ST-8333	RO Filter Bracket	ST-8333	Yes	
28	CT-2056-A	RO Bladder Tank (4 gallon)	CT-2056-A	Yes	
29	ST-8337	RO Bladder Tank (4 Gallon) - Holding Bracket 1	ST-8337	Yes	
30	ST-8338	RO Bladder Tank (4 Gallon) - Holding Bracket 2	ST-8338	Yes	
31	10-3083	Unit Rubber Feet	ST-8016	Yes	
32	NA	Base Cabinet Bottom Shelf	ST-8269	No	
33	PL-1375	Leak Containment Tray	PL-1375	Yes	
34.1	12-3180	Leak Containment Tray Clip (sensor 0.5mm)	ST-8207-CN	Yes	
35	PL-1339	Base Cabinet Plastic Side Panel - Left	PL-1339	Yes	
36	NA	Base Cabinet Support Frame	ST-8270	No	
37	NA	Base Cabinet Back Panel	ST-8273	No	
38	10-3067	Bulkhead Union 1/4" x 1/4" John Guest P/N PI1208S	PU-4028	Yes	
38.1	AK-0014-B	Flow Restrictor for Sparkling Water (1,8 mm hole)	AK-0014-B	Yes	
39	NA	Base Cabinet Back Panel	ST-8342	No	
Not shown	PU-4031	JG LLD PE Tube - Blue O.D.1/4"John Guest P/N PE-08-BI-1000F-B	PU-4031	No	

Not shown	10-7040	Silicon Tube 5/16" for hot water	PU-4064	Yes	
Not Shown	10-3007	Power Cord 120V – 1825 mm	EL-5001-B	Yes	

## WL400 STANDARD WATER FLOW DIAGRAM

There is a 100 Gallons per day (Gpd) / 378.5 Liters per day (Lpd) flow restrictor inline after the Main Unit bulkhead inlet fitting on all **WL400 Treatment Systems**.

Flow Restrictor  
Part Number AK-0014-B

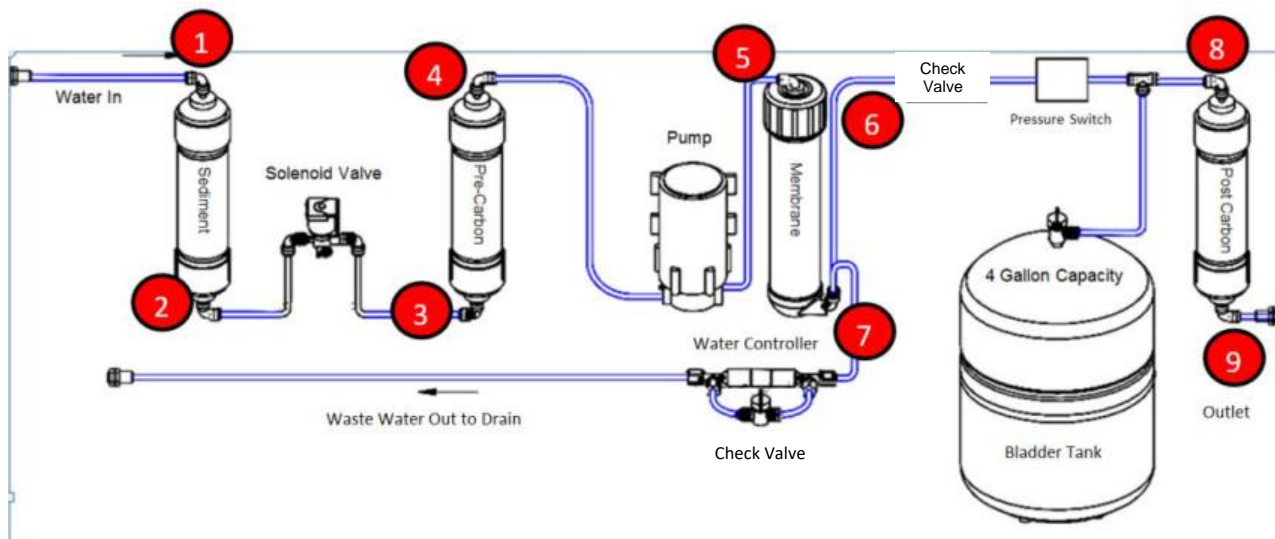
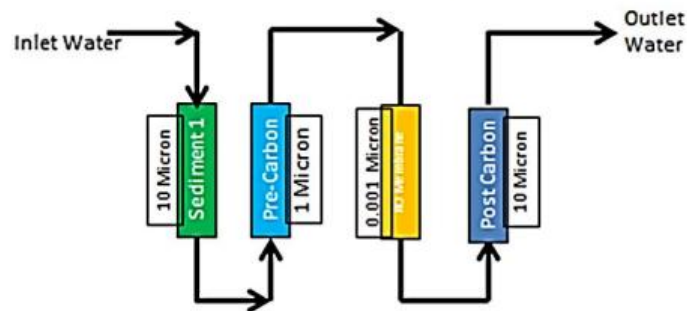

## WL400 COUNTER TOP ELECTRICAL DIAGRAM

**⚠ DANGER!** HIGH VOLTAGE ELECTRICAL HAZARD. PCB (Printed Circuit Board) contains High Voltage. Only trained and qualified technicians should attempt live testing.

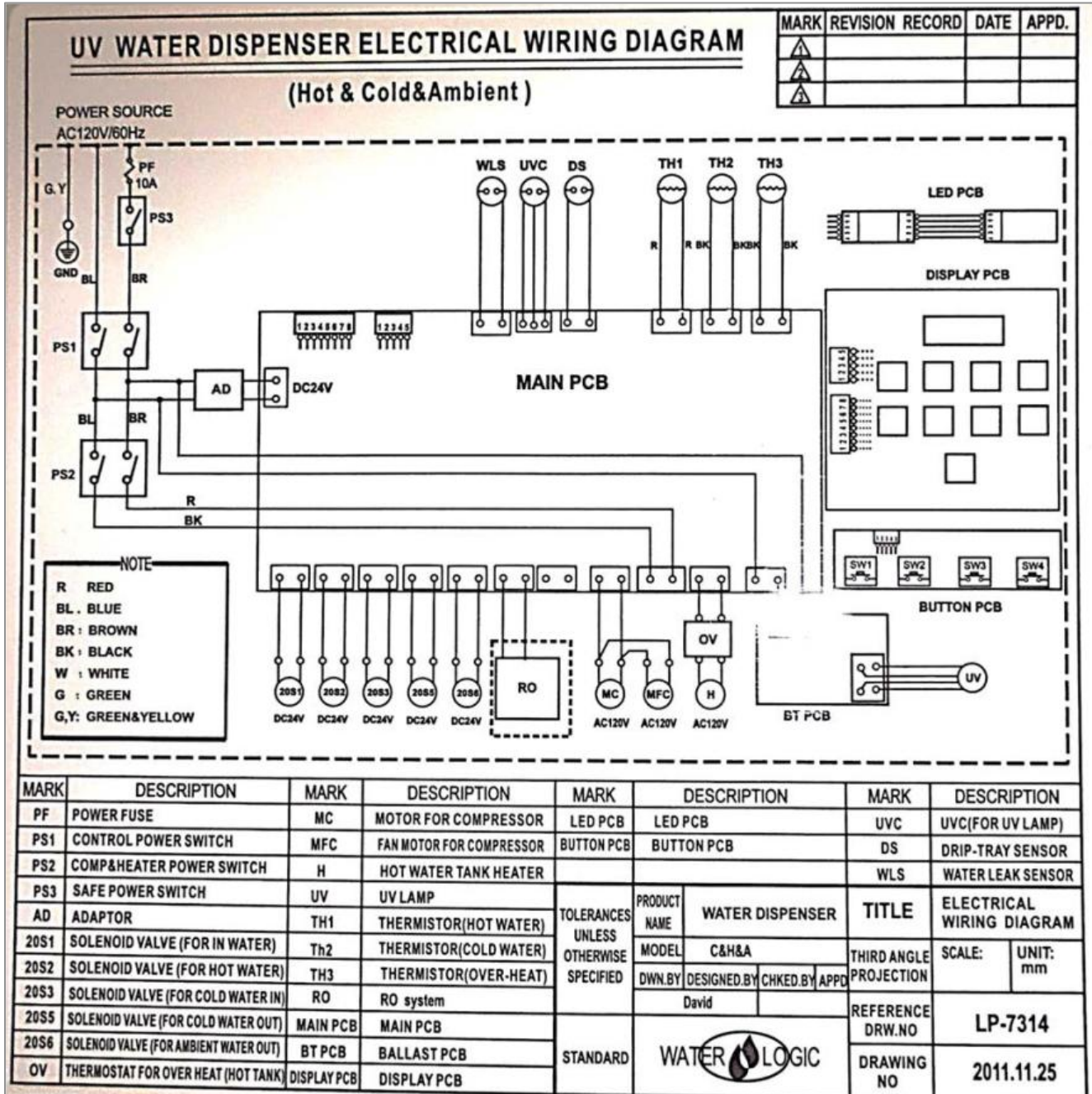



## RO QUICK GUIDE OVERVIEW

The **WL400 Water Treatment System** contains a high capacity Reverse Osmosis Filtration System installed in the Base Cabinet.

Efficiency is improved by utilizing the on-board booster pump to optimize the osmotic pressure, and a 4 Gallon Bladder Tank is included in the Base Cabinet.



The Filtration system has 4 Stages of Filtration with 75 Gallons per day capacity combined with exclusive Firewall™ Purification.

Stage 1 – Sediment Filter; Removes unwanted particles and particulates down to 10 microns.

Stage 2 – Pre-Filter; Granular Filter removes unwanted chlorine, odor and bad taste

Stage 3 – RO Membrane; 0.001 Micron filtration to remove total dissolved solids from the water.

Stage 4 – Post Filter; Carbon “polishing filter” to improve the taste of the water.

Final Barrier – Firewall™ Advanced Water Purification; Acts as the Final Barrier at the Point of Use.

### RO Membrane Part No. 15-3020

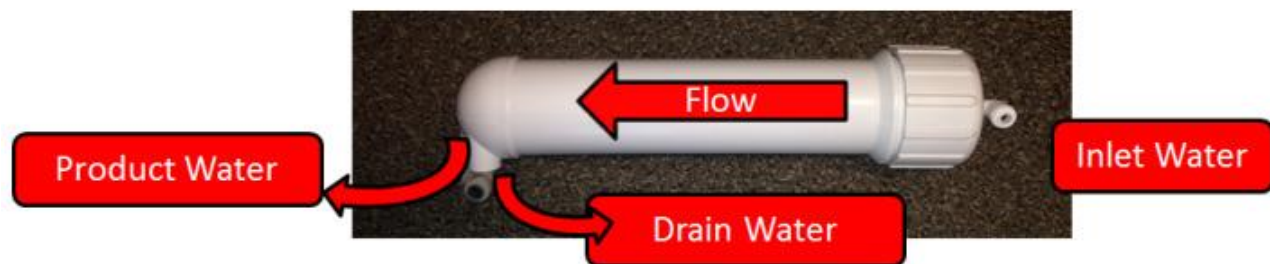

## BASE CABINET SIDE REMOVAL

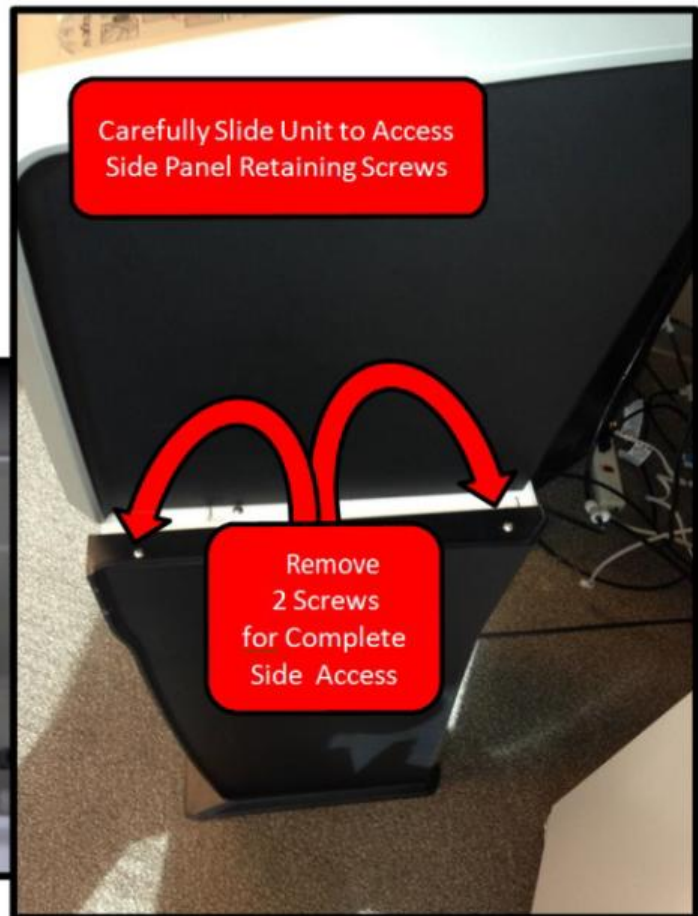
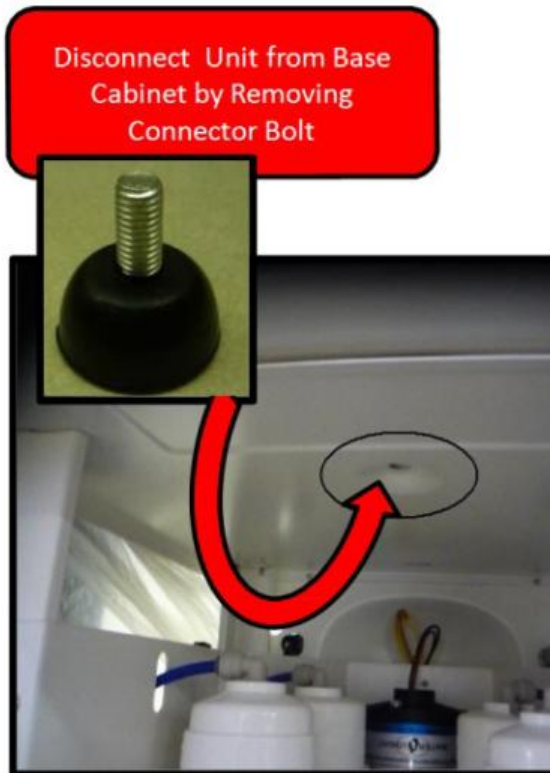

**BASE CABINET CONFIGURATION**

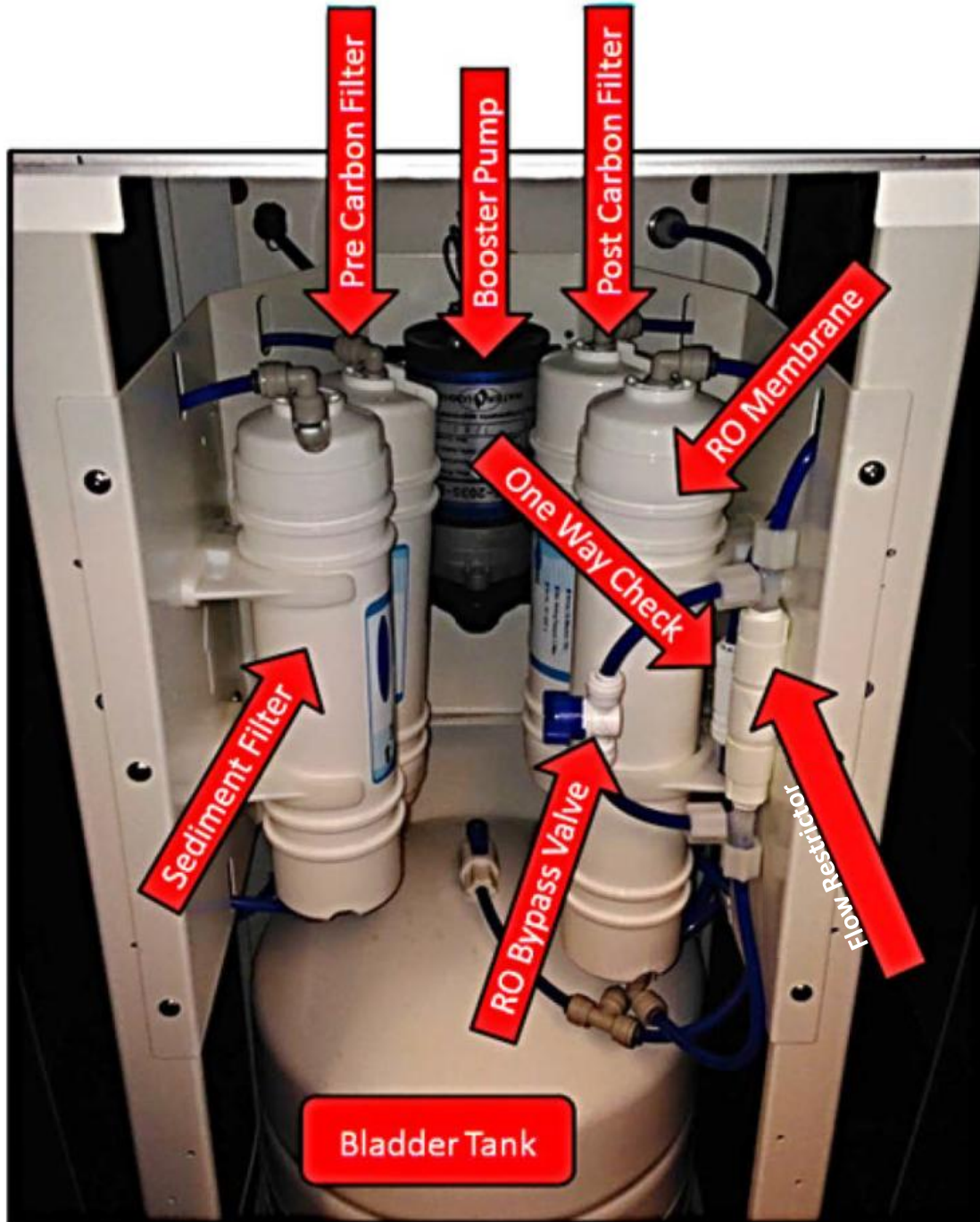

## RO SETUP AND FILTER CHANGE

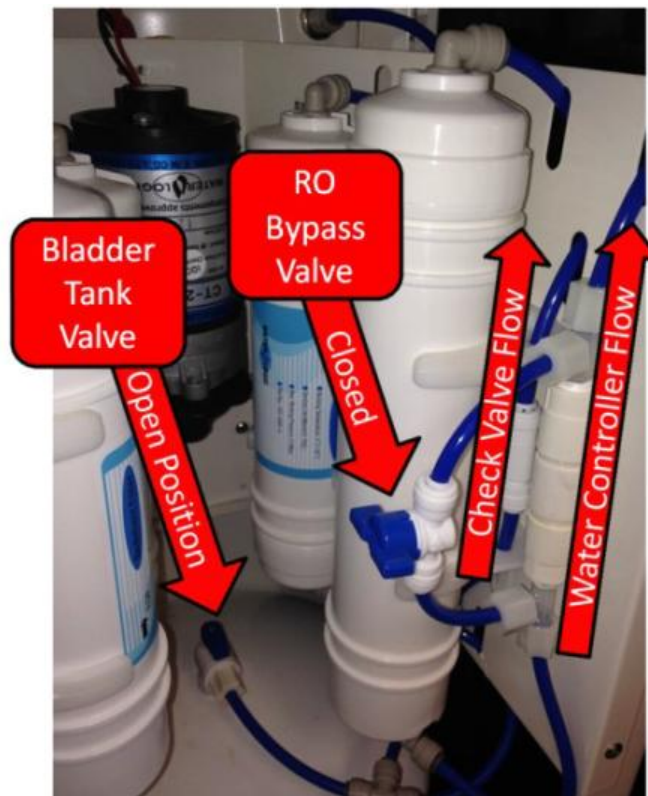

1. Remove Front Panel from Base Cabinet
2. Isolate Water Supply
3. Remove Pre-Carbon and Post-Carbon Filters and clear carbon fines by flushing 5 gallons on water through each filter individually to drain.
4. Reinstall Pre-Carbon and Post-Carbon filters.
5. Close RO bypass valve and bladder tank valve (See photo above)
6. Flush RO Membrane to drain for a minimum of 4 hours or until TDS reduction is at desired level (>90%). Water should be draining from both the water out line and drain line.
7. Open Bladder Tank Valve and turn on water supply. Ensure RO bypass valve stays in the Closed Position.
8. Allow up to 1 hour for empty bladder tank to fill if necessary.

## INSIDE LEFT-SIDE CABINET CONFIGURATION

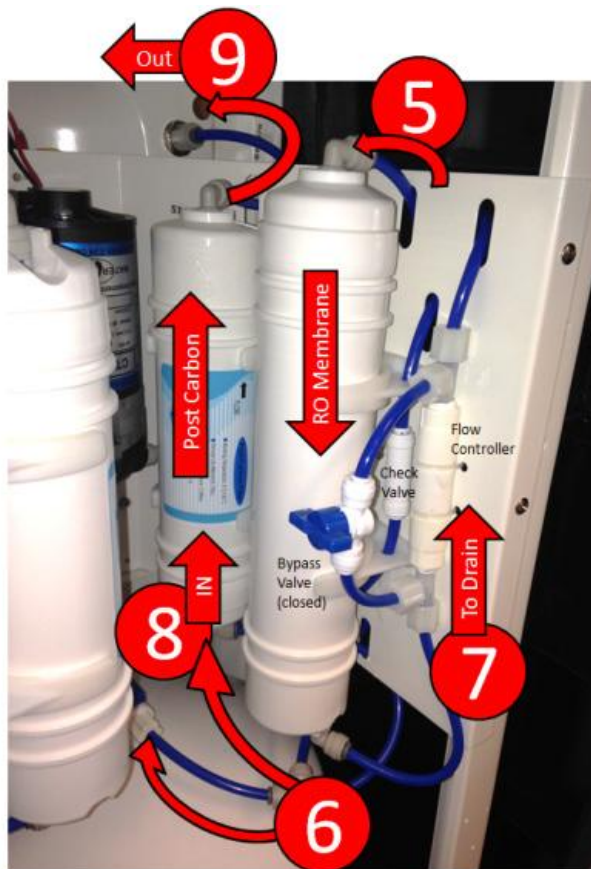
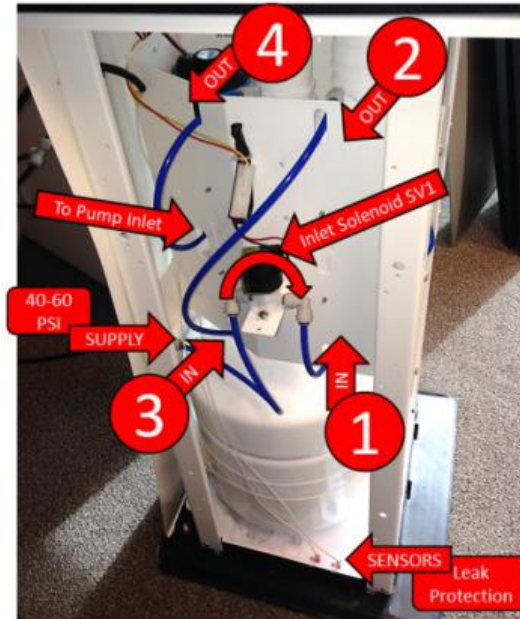

**INSIDE RIGHT-SIDE CABINET CONFIGURATION**

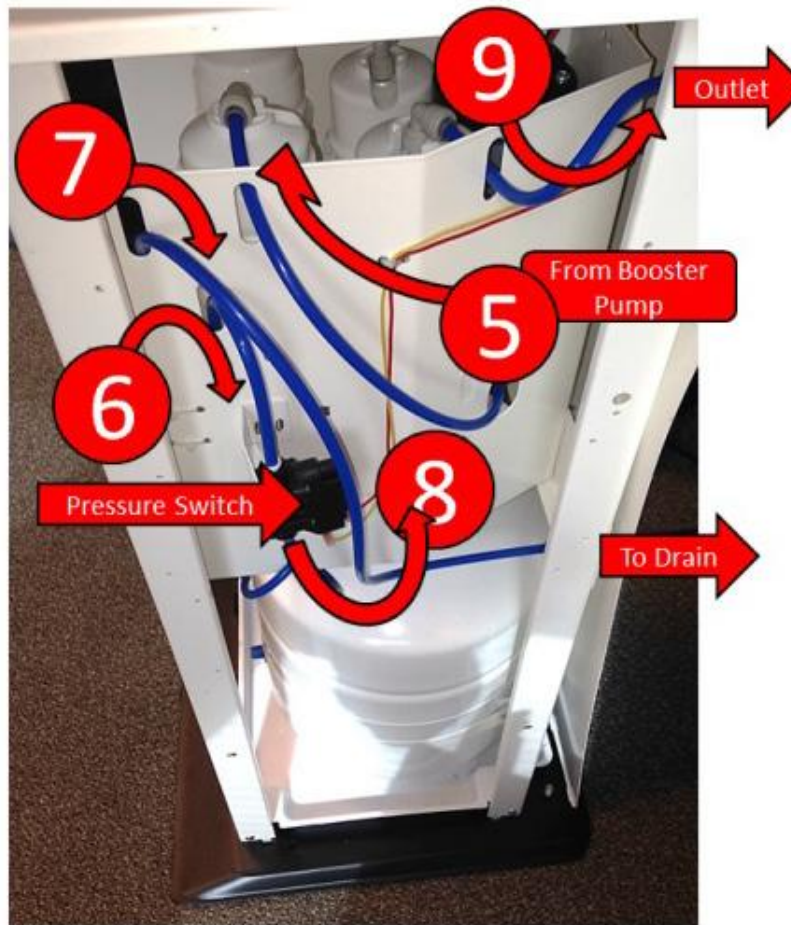

## REPLACING RO MEMBRANE

### Original Filter Configuration

Part No	Description	WLCP Part No
RO-0001A	Sediment Filter	10-8050
RO-0002A	Pre-Carbon Block	10-8055
RO-0004C	RO Membrane	10-8060
RO-0005A	Post Carbon Black	10-8065
CT-2090-C	13W UV Lamp	10-8075



**Original RO Membrane**  
 WLCP PN 10-8060 (Factory PN RO-0004C)  
 One Piece 100 Gpd (378.5 Lpd) RO Membrane

### NEW RO Membrane Kit – P/N 10-8061

Kit 10-8061 consists of:

Quantity	WLCP Part No	Description
1 each	15-3001 (R-RO)	Dow Film Tec 75 Gpd RO Membrane
1 each	15-3020 (R-P001)	Ro Membrane Housing (2 piece)
3 each	JG 480821S	¼" Tube * 1/8" NPT Rigid Elbows
1 each		RO Membrane Instructions



**Replacement Membrane Kit**  
 WLCP Part Number 10-8061  
 One Piece 75 GPD RO Membrane

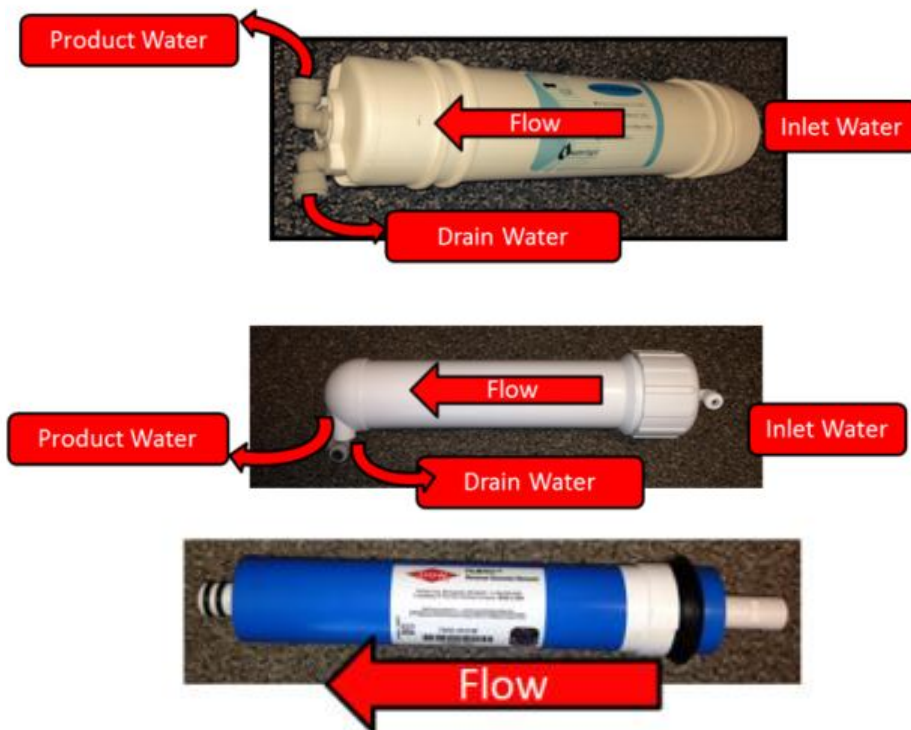

OLD RO Membrane # 10-8060 Installed

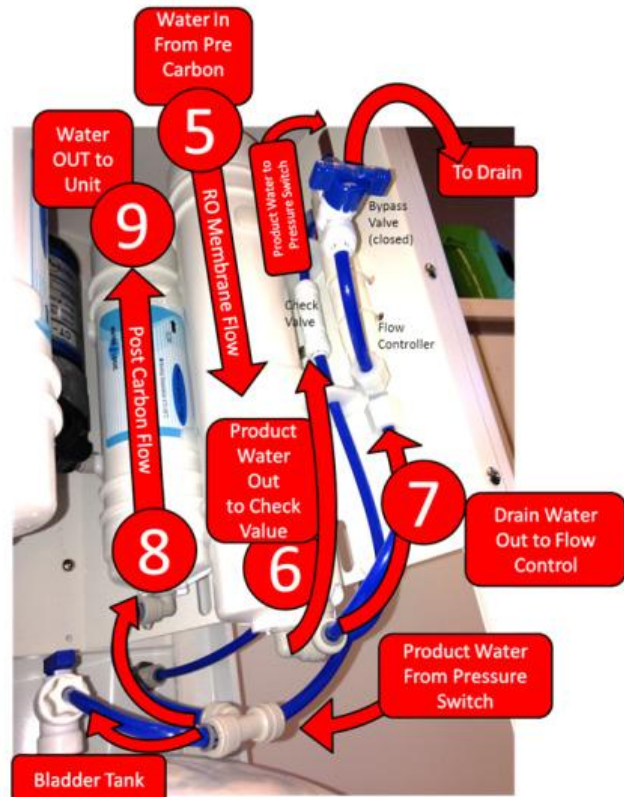

NEW RO Membrane # 10-8061 Installed

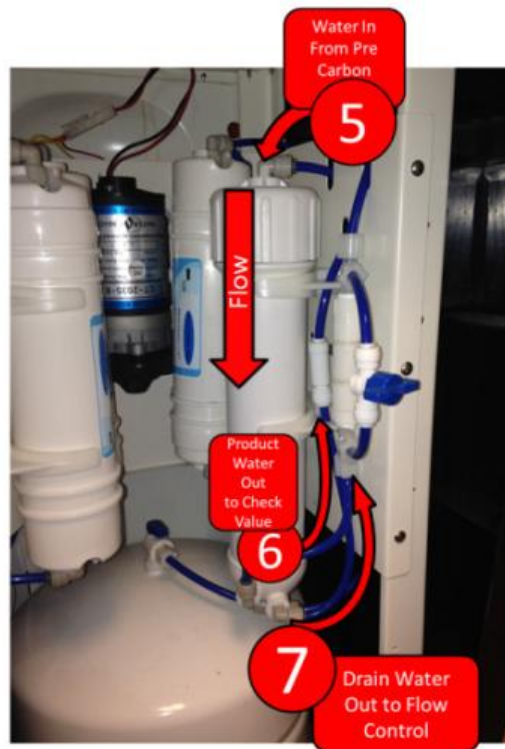



## PRE-INSTALLATION PROCEDURES

**⚠ DANGER! ELECTRICAL SHOCK HAZARD.**

*Only qualified personnel who have read and understand this entire manual should attempt to install, or service this unit, failure to do so could result in death or serious injury.*

**⚠ WARNING! ALWAYS SANITIZE BEFORE USE.**

*Sanitize before use to eliminate any potential microbiological contaminants.*

*Green Compressor/Heater Switch must be in the O=OFF position while the Hot Tank is empty. Damage could occur within one minute and the two Hot Tank Overload Devices (High Safety Limit) require manual reset if heater is turned on with an empty Hot Tank.*



**⚠ CAUTION! DRIP TRAY DRAIN.**

*If you intend to provide a drip tray drain for your customer, be aware that you will be called multiple times per month to service and unclog the tubing leading away from the drip tray to drain. Users will clog the drain with paper clips, erasers, napkins, tea bags, gum, and various other intended items. Waterlogic recommends you establish a minimum of weekly visits to the machine for cleaning of the drip tray drain.*

### Sanitization of Machine

#### Materials Needed:

- Personal Protective Equipment. Rubber or Nitrile Safety Gloves and Protective Eyewear
- Phillips Screwdriver
- Temperature Gauge
- Water Pitcher or Container to collect water from the faucet
- 5-gallon container or drain basin
- Sanitizer - Household Bleach (5.25% Sodium Hypochlorite) or Citric Acid Based Cleaner
- ¼" Plastic Tubing, at least 4 feet in length, and assorted ¼" quick connect fittings
- TDS Meter and Test Strips for measuring chlorine – Optional
- Sanitizing Cartridge

1. Unpack the **Waterlogic WL400** and check exterior for damage.

Sanitize using a Household Bleach (5.25% Sodium Hypochlorite solution) or other approved cleaner throughout the cold and sparkling water circuits. Follow all instructions on the sanitizer and flush with fresh water through the faucet until odor and taste is acceptable.

**⚠ WARNING! USE PROPER PERSONAL PROTECTIVE EQUIPMENT**

*Always ensure proper ventilation and use proper personal protective equipment such as gloves and eye protection when using chemicals. Refer to Material Safety Data Sheet for specific requirements of each chemical product. Take all necessary precautions to prevent sanitizer from contacting eyes, clothing, and any other surfaces in could damage (carpets).*

- Put 1 teaspoon of sanitizer per directions or use Bleach Solution (1 teaspoon = 1/6 oz. = 5 ml = ½ cap full) of household bleach (Sodium Hypochlorite 5 - 10% Concentration) in the Sanitizing Cartridge. Always ensure sanitizer is compatible with stainless steel and acetyl plastic.
- Connect sanitizing cartridge to inlet water supply and connect to inlet bulkhead fitting on back of unit. Turn on water supply.
- Connect power to **WL400 Water Treatment System**. Turn on Red Power Switch. DO NOT TURN ON GREEN HEATER/COMPRESSOR SWITCH AT THIS TIME.

**⚠ CAUTION!** *NEVER TURN ON HEATER BEFORE FILLING HOT TANK.*

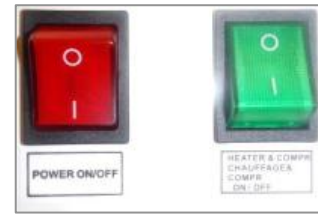

*Green Heater/Compressor Switch must be in the O=OFF position while the hot tank is empty. Damage could occur within one minute and the overloads (high limit) will require manual reset if heater is turned on with an empty hot tank.*

#### Fill the Cold Circuit with Sanitizer

- Depress the Main Dispensing Button on the Front Control Panel until cold water/sanitizing solution comes out the faucet. **NOTE:** Container and drain basin will be required to catch the water from the faucet.

**⚠ WARNING!** *Use Personal Protective Equipment. Gloves and Eye Protection Required. The first 2 or 3 gallons of water will contain concentrated sanitizer. Use extreme care!*

- Turn off water supply and remove Sanitizing Cartridge from inlet water supply. Reconnect water supply to Inlet Bulkhead Fitting.

#### Flushing the Sanitizer from the Machine

- Flush thoroughly per filter manufacturers' recommendation with fresh water to drain.
- Once flushed, install the Filters. Following the flow direction on the filter.

**NOTE:** Filters should not be flushed prior to 24 hours before installation to limit Microbial Growth.

- Connect **WL400 Water Treatment System** to power.

## Flush Filters

**⚠ CAUTION! FILTER FLUSH REQUIRED.**

*In order for our filters to perform as represented and to provide the best quality water possible, it is essential that filters be replaced periodically. The frequency of filter changes depends upon your water quality and your water usage. For example, if there is a lot of sediment and/or particles in your water, then you will have to change your filters more frequently than a location with little to no sediment. Be sure to replace your filters whenever you notice a decline in the performance, whether it is a drop in flow rate and/or pressure or an unusual taste in the water.*

10. **⚠ CAUTION! NEVER TURN ON HEATER BEFORE FILLING HOT TANK.**

*Green Heater/Compressor Switch must be in the O=OFF position while the hot tank is empty. Damage could occur within one minute and the overloads (high limit) will require manual reset if heater is turned on with an empty hot tank.*

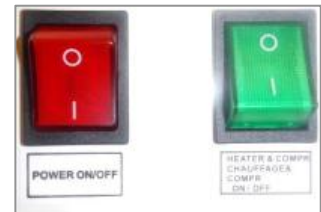

11. Remove Front Panel from Base Cabinet opening Top of Panel and Removing Slide Bar.



12. Attach **WL400 Water Treatment System** to Base Cabinet with Locking Bolt provided.

13. Connect wires (quick connect clips) on back of unit from Base Cabinet to **WL400 Water Treatment System**.

14. Remove Pre-Carbon and Post Carbon filters and flush 5 gallons of water through each filter separately.

15. Reinstall Pre and Post Carbon Filters.

16. Close RO bypass and bladder tank.



Bladder Tank

RO Bypass



17. On Back of Cabinet, connect two pieces of tubing to the RO Drain and Water Out line and run to external drain.



18. Connect power cord to **WL400 Water Treatment System** and turn on Red Power Switch.

19. Connect power to **WL400 Water Treatment System**. Turn on Red Power Switch *I=ON*. DO NOT TURN ON THE GREEN HEATER/COMPRESSOR SWITCH

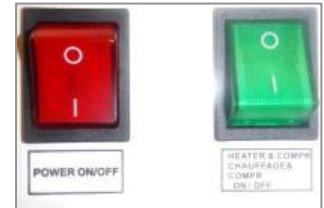

**⚠ CAUTION! NEVER TURN ON HEATER BEFORE FILLING HOT TANK.**  
*Green Heater/Compressor Switch must be in the O=OFF position while the hot tank is empty. Damage could occur within one minute and the overloads (high limit) will require manual reset if heater is turned on with an empty hot tank.*

20. Connect supply water to Water In Fitting on back of cabinet. Turn on water supply and flush RO system to drain for 4 hours. Water should be draining from both Water Out line and the Drain Line.

21. After 4 hours of flushing, turn Off Incoming Water. Connect water line from the Base Cabinet to Water In fitting on **WL400 Water Treatment System**.

22. Open Bladder Tank and turn on supply water.

23. Allow Bladder Tank to fill for 1 hour.

24. Fill Hot Tank for approximately 1 minute. Depress both the “Hot” and “Extra Hot” buttons to dispense. Red light should illuminate above the dispensing area after a 2 second delay.

25. Fill cold tank for approximately 2 minutes. The Blue Light should illuminate above dispensing area.



26. Turn on Green Heater/Compressor Switch.

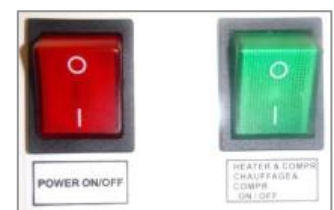

### Fill the Hot Tank

27. Press the Hot Water Select Button, followed by the main dispensing button to fill the hot tank. Water will dispense from the faucet once the hot tank is full. Flush until water is clear.

**⚠ WARNING! HOT CIRCUIT IS NOT SANITIZED.**

Water in the hot circuit is not sanitary until the temperature exceeds 171°F (77°C) for at least 5 minutes.

### UV System Functional Test

**⚠ WARNING! ULTRAVIOLET RADIATION.** Protect your skin and eyes against ultraviolet rays. Never look directly at an operating UV light. Disconnect wiring before removing.

28. Remove UV Firewall™ Lamp from Firewall™ housing. Remove Top Cover from Firewall™ housing. Carefully remove Quartz Sleeve Spiral from Firewall™ Housing and inspect for cracks or other damage. Reinsert Quartz Sleeve Spiral, replace top cover of housing. Inspect UV lamp and reinsert into Housing.
29. Press Dispensing Button and check for blue glow from top of Firewall™ Housing and at Faucet dispensing area to ensure UV lamp is operational.
30. Disconnect UV lamp to test UV lamp sensor operation. Unit should alarm and UV Icon on display will light.



31. Disconnect power to **WL400 Water Treatment System**.
32. Reconnect UV lamp.
33. Connect power to **WL400 Water Treatment System**.

### Compressor Test

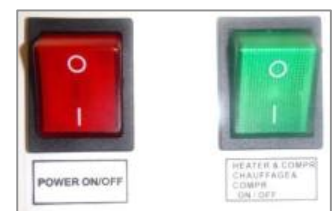

34. Switch Green Heater/Compressor to on *I=ON* position. Always ensure tanks are full of water before turning on the heater or the overloads (high limit) will open and require manual reset. If the wire condenser at back of the unit is warm, the refrigeration system is working.
35. Once the **WL400 Water Treatment System** reaches its target temperature, the compressor will shut off. Draw a glass of cold water and verify it has been chilled to proper temperature.

### Heater Test

36. Always ensure tanks are full of water before turning on the Heater or the Overload (High Limit) will open and require manual reset. It will take the heater approximately 10 minutes to heat the water from ambient 75°F (24°C) to the factory set point of 185°F (85°C). Dispense a cup of hot water to ensure the temperature/odor/taste is acceptable.

**⚠ WARNING! VERY HOT WATER CAN BURN OR SCALD.**  
*Hot water should be dispensed carefully into insulated container to avoid*

## WL400 DRAINING INSTRUCTIONS

### Draining Notes

Drain the **WL400 Water Treatment System** for transportation.

**⚠ WARNING!** *STORE UNIT EMPTY. ALWAYS SANITIZE BEFORE REUSE.*

*The unit must be completely drained and sealed before storing to avoid stagnation and reduce microbial growth).*

Prior to draining the Hot Tank, turn Off the Green Compressor / Heater switch (*O=OFF*), and dispense 2 liters of hot water from the machine. As hot water is dispensed from the faucet of the unit, colder water will be introduced into the hot tank. Since Green Compressor / Heater switch is turned off, the heater will not energize and heat the incoming tap water. Following this precaution prevents exposing personnel and equipment (drains, catch basin, etc.) to scalding hot water.

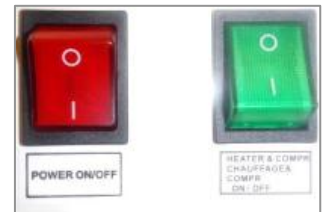

### Disable Cold and Hot Tanks

1. Turn off the Green Heater / Compressor switch to disable the heater and compressor.
2. Dispense 1 liter of water through the hot tank to cool the water temperature in the hot tank and avoid burns.

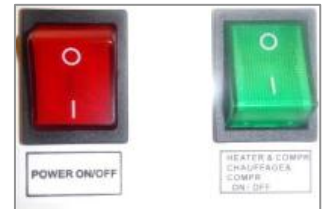

**⚠ WARNING!** *WL400 Water Treatment System produces VERY HOT WATER up to 203°F (95°C). Water above 125°F (52°C) can cause severe burns or scalding. Hot water should be dispensed carefully into insulated container to avoid injury.*

### Turn Off Water Supply and Bleed Water Pressure

3. Isolate the unit from feed water by turning off the supply.
4. Turn off Bladder Tank.
5. Dispense cold still water to relieve any pressure built up in the system.
6. Remove screws from Slide Locks located near dispenser.
7. Push Slide Locks inward toward dispensing area.
8. Pull cover forward and lift from the front to open Top Cover.



9. Disconnect Cold Line from top of Cold Tank.
10. Remove Drain Caps and Plug from Cold Water Tank Drain on the back of the **WL400 Water Treatment System**.
11. Open Bladder Tank.
12. After unit has finished draining, replace Plug and Drain Caps.
13. Reconnect tubing to Cold Tank.
14. Close lid, close locks and replace screws in Top Cover.





## **BASE CABINET ASSEMBLY**

1. Insert the four corner supports into the base panel. Secure with one screw to the bottom of each upright.

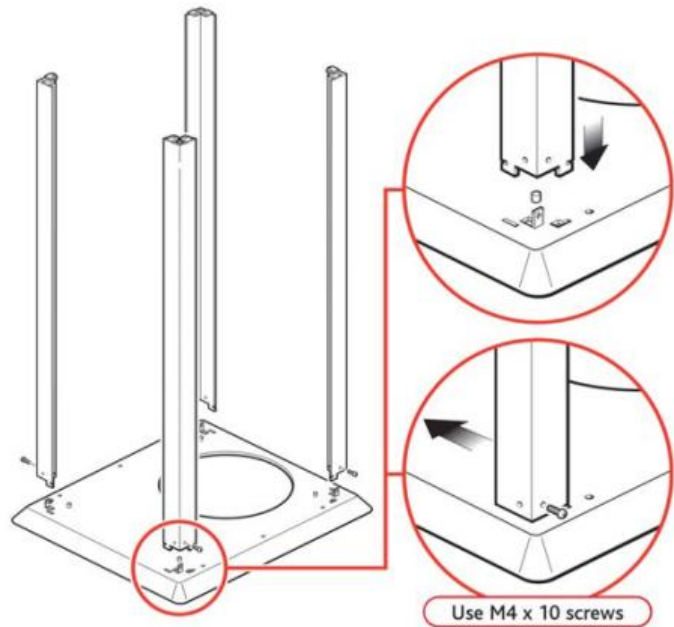

2. Place Top Panel on to the corner supports. Secure with two screws to the top of each upright.

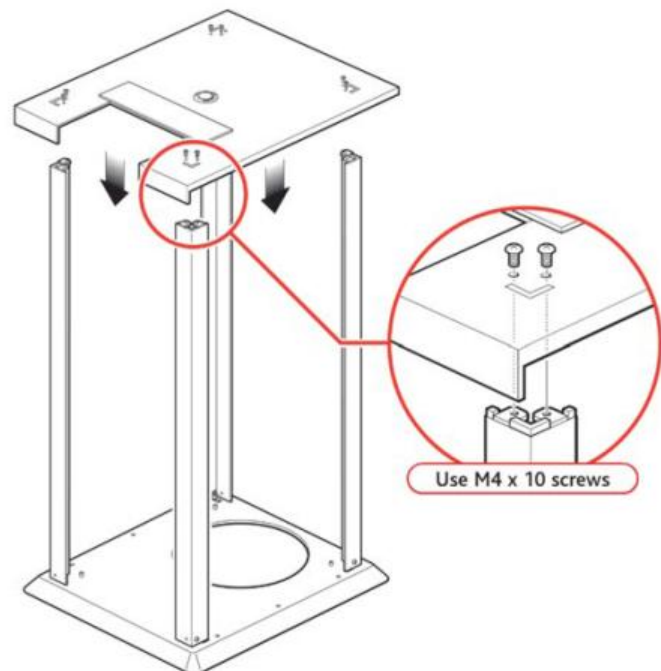

3. Fix the back panel into the base panel and secure with four screws.

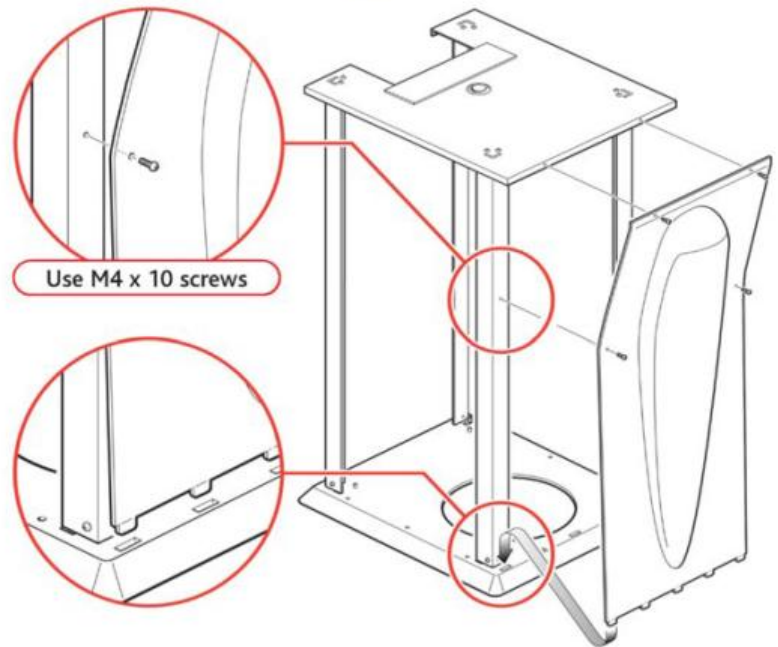

4. Fix the side panels into the base panel and secure with two screws in each through the top panel.

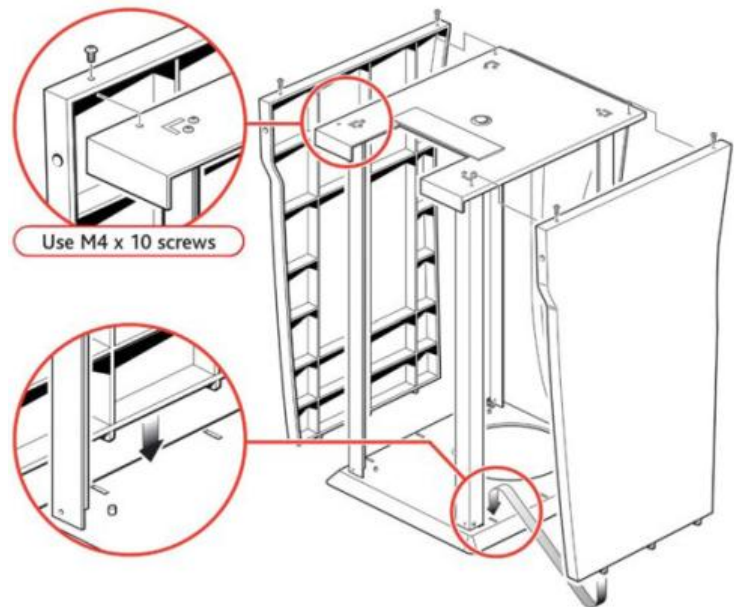

5. Place the WL400 Counter Top onto the base cabinet. Secure as shown.

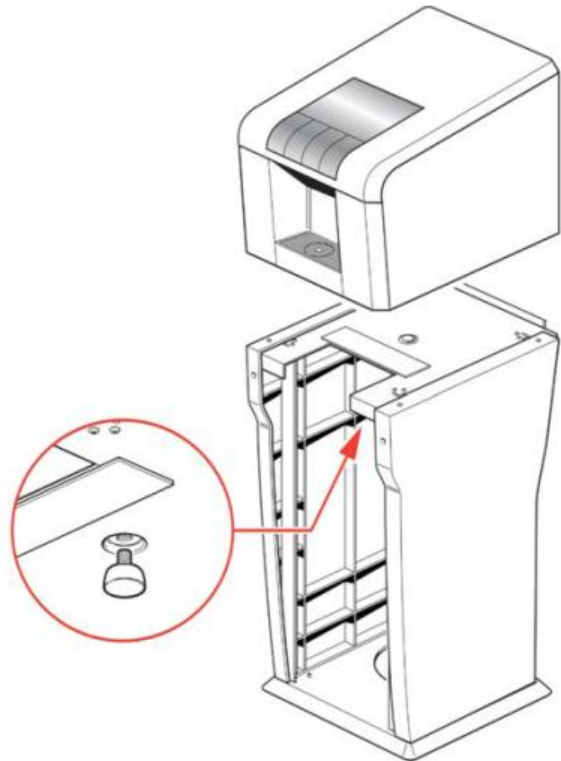

6. Attach the door strap to the door using the three short screws. Align bottom of door into the base panel and attach door strap into cabinet housing.

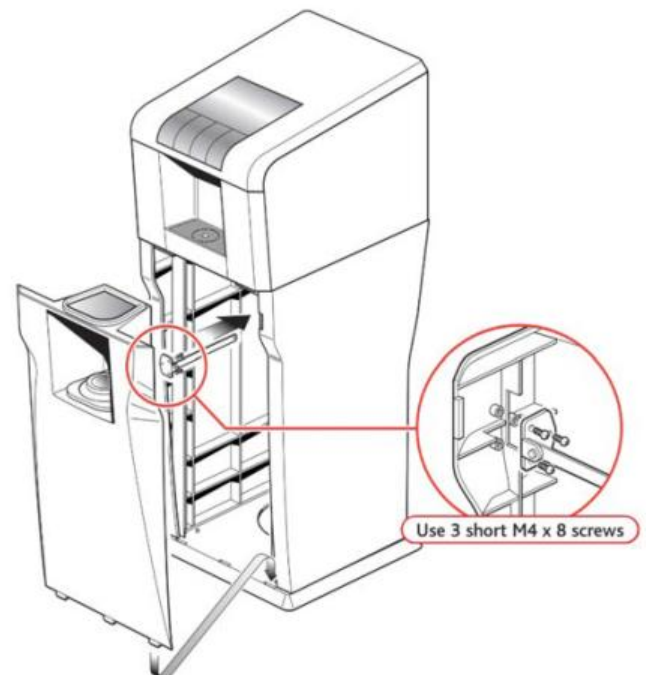

## **INSTALLATION PROCEDURES**

### **Safety and Installation Guidelines**

Ensure all Local, State, and Federal Laws and Codes including health and safety guidelines are met when installing **Waterlogic** Equipment. Only qualified service technicians should attempt installation and service of **Waterlogic** Equipment.

**⚠ WARNING! ELECTRICAL SHOCK HAZARD.** Always unplug (isolate from power supply) to prevent electrical shock except where electrical tests are specified.

**⚠ WARNING! IMPROPER SUPPLY OR CONNECTION CAN RESULT IN RISK OF SHOCK.** Connect to a 15 amp 120V 60Hz properly grounded outlet (GFI is recommended). Ensure polarity is correct and always use a 3-prong outlet. Consult a qualified electrician if you have any questions.

**⚠ WARNING! USE ONLY Waterlogic SUPPLIED POWER CORD.** Locate system within 5 feet of power supply. Never use an extension cord or adapter. Do not use a damaged power cord or plug. Keep power cord out of heavy traffic areas and away from heat sources. Do not, under any circumstances, remove ground prong or alter the power cord. Never pull the power plug from the outlet with a wet hand or allow the plug to get wet. Failure to use the supplied power cord will void UL Certification and Warranty.

**⚠ CAUTION! INDOOR USE ONLY.** Never expose to direct sunlight, heat sources, or ambient air temperature above 100°F (37°C) or below 35°F (2°C). Install indoors and keep unit away from excessive humidity. Never expose to freezing temperatures. Ensure there is adequate clearance around the unit to allow refrigeration system condenser to dissipate heat. Warmer environments require more clearance around the unit. Minimum clearance around all surfaces of the machine is 2-inches. Installs where the ambient temperature exceeds 80°F, require a minimum of 4-inches clearance for proper heat dissipation and efficient operation.

**⚠ CAUTION! USE A WATER PRESSURE REGULATOR.** **Waterlogic** will not be responsible for injury or damage caused by excessive water pressure. Operating pressure must be 40 psi to 60 psi. Be aware any of potential pressure surges caused by building/municipal pumping stations.

**⚠ CAUTION! USE UV STABILIZED SUPPLY LINES.** Feed the unit with a potable ambient or cold water supply only. Feed water over 100° F (37°C) can damage the treatment components. Water block devices and external leak detectors are strongly recommended. Locate the unit as close to the water supply and the electrical connections as possible.

**⚠ WARNING! STORE AND TRANSPORT UNIT EMPTY. ALWAYS SANITIZE BEFORE USE.** The unit must be completely drained and sealed before storing to avoid stagnation and reduce microbiological contamination (potential bacterial growth). Sanitize before use to eliminate any potential microbiological contaminants

Pre-installation and sanitization procedures as prescribed in this manual must be performed before installing the **WL400 Water Treatment System**

Always install indoors and place the **Waterlogic WL400 Water Treatment System** on a firm, flat and stable surface.

1. Unpack the **Waterlogic WL400 Water Treatment System** and check exterior for damage.
2. Remove Front Panel from Base Cabinet opening Top of Panel and Removing Slide Bar.
3. Remove **WL400 Water Treatment System** from packaging and place on top of base cabinet.



4. Attach **WL400 Water Treatment System** to base cabinet with Locking Bolt provided.

- a) Remove screws from locking slides located under Front Cover adjacent to faucet.

- b) Unlock slides and open Top Cover of **WL400 Water Treatment System**.

- c) Pull cover forward and lift from the front to open top cover.

- d) Locate wires and run them through.



5. Connect Wires (Quick Connect Clips) on back of unit from Base Cabinet to **WL400**.
6. Remove Pre-Carbon and Post-Carbon Filters and flush 5 gallons of water through each filter separately.

7. Reinstall Pre and Post Carbon Filters.

8. Close RO Bypass and Bladder Tank

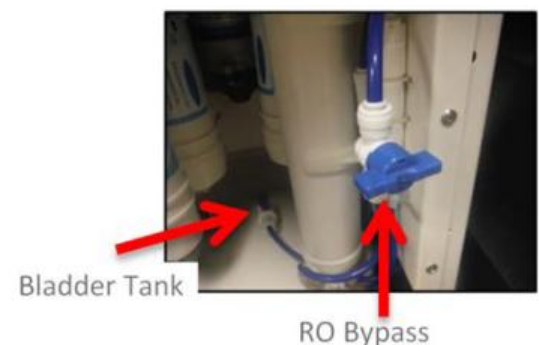

9. On Back of Cabinet, connect 2 pieces of Tubing to RO Drain Line and Water Out Line and run to external drain.

10. Connect the power lead and insert it into the rear of the machine. Turn on the Red Power Switch *I=ON*. Do NOT turn on the Green Heater / Compressor Switch.

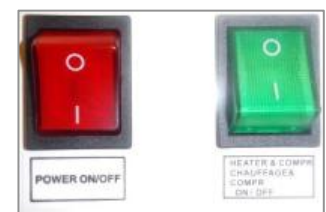

**⚠ CAUTION! NEVER TURN ON HEATER BEFORE FILLING HOT TANK.**

*Green Heater/Compressor Switch must be in the O=OFF position while the hot tank is empty. Damage could occur within one minute and the overloads (high limit) will require manual reset if heater is turned on with an empty hot tank.*

11. Connect supply water to water in fitting on back of cabinet. Turn on the Water Supply and flush RO system to drain for 4 hours. Water should be draining from both Water Out Line and Drain Lines.
12. After 4 hours, turn off Incoming Water. Connect Water Out Line from Base Cabinet to drain water in fitting on **WL400 Water Treatment System**.
13. Open Bladder Tank and turn on supply water.
14. Allow bladder tank to fill for 1 hour.
15. Fill Hot Tank (Approximately 1 minute). Depress both Hot and Extra Hot Buttons to dispense. Red light should illuminate above dispensing area after 2 second delay.

16. Fill Cold Tank (Approximately 2 minutes). Blue light should illuminate above dispensing area.



17. Turn on Green Heater/Compressor Switch. I=ON.

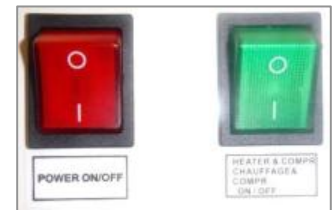



## FAULT CODE TROUBLESHOOTING INDEX

1. Icon and Alarm on continuously – Leak Detector Sensor Alarm
2. Icon ON Continuously, Alarm for 20 Seconds – the Firewall UV system is not detecting adequate dose of UV to ensure safe water

### 1. **FAULT CODE:** Icon and Alarm on continuously – Leak Detector Sensor Alarm

There are two leak detector sensors in the *WL400 Water Treatment Systems*.

Possible Reason	Solution
Leak Tray Full	<p>Check for water in base cabinet by opening and removing front cover.</p> <p>If water is found in leak tray, dry out leak tray.</p> <p>Unplug unit to reset fault and determine where the leak is.</p>
Leak Tray Full – <b><u>with no alarms</u></b>	<p>Verify the drip tray leak clips are installed.</p> <p>If the drip tray leak clips are installed, the water TDS may be too low. You may need to bend the drip tray sensor tabs inward (closer together) to improve the performance of the signal returning to the board.</p> <div style="display: flex; justify-content: space-around;">   </div>
`Water in Base Cabinet	<p>If no water is found in the base cabinet, open Top Cover of <b>WL400 Water Treatment System</b> and remove Right Side Panel to determine where leak is.</p> <p>If water is found, dry out leak tray, unplug unit to reset fault and determine where the leak is.</p>

2. **FAULT CODE: Icon On Continuously, Alarm for 20 Seconds**

Possible Reason	Solution
UV Lamp Alarm	Replace Lamp / Sensor to reset.



## POWER TROUBLESHOOTING INDEX

1. Red Power Switch, Green Heater and Compressor Switch and the LEDs on the Front won't light
2. Red Power Switch, Green Heater and Compressor Switch are lit but the red LED on the Front is not lit
3. Compressor Runs but does Not Chill
4. Compressor is Not Running

### **1. Red Power Switch, Green Heater and Compressor Switch and the LEDs on the Front won't light**

Possible Reason	Solution
Circuit Breaker	Check the Circuit Breaker
Fuse is Blown	Replace Fuse
Defective / Loose Power Cord	Check that power cord is properly plugged in. If it is properly plugged in, use a different power cord to verify.
Failed Power Socket with, ElectroMagnetic Interference Filter (EMI)	Replace Power Socket with, ElectroMagnetic Interference Filter (EMI)
Defective Red Power Switch	Replace Red Power Switch
Defective Green Heater and Compressor Switch	Replace Green Heater and Compressor Switch



## 2. Red Power Switch, Green Heater and Compressor Switch are lit but the red LED on the Front is not lit

Possible Reason	Solution
Bad Transformer	Replace Transformer
Black Power Connector to the PCB is not properly connected	Properly connect.
Bad Front PCB	Replace Front PCB
Defective Red Power Switch	Replace Red Power Switch
Defective Green Heater and Compressor Switch	Replace Green Heater and Compressor Switch

## 3. Compressor Runs But Does Not Chill

Possible Reason	Solution
Condenser is dirty	Clean the condensing coil of any obstructions or dust.
Reduction of airflow into unit.	Make sure unit is not under minimum ventilation requirements (2 to 4 inches).
Compressor is running very hot.	Low or lost refrigerant. Refrigerant recharge required.

#### 4. Compressor is Not Running

Possible Reason	Solution
Green Heater and Compressor Switch button on unit is in the off position	Turn Green Heater and Compressor Switch on. <i>I = ON</i> 
Compressor Starting Circuit	Turn Green Heater and Compressor Switch off. <i>O = OFF.</i> Remove the compressor cap on side of the compressor; Disconnect the black and red terminal connectors; Inspect the starter and overload relay for any defects. Replace components(s) as needed. Turn Green Heater and Compressor Switch on. <i>I = ON and</i> retest compressor operation.  

## **DISPENSING TROUBLESHOOTING INDEX**

1. Irregular / Intermittent Dispensing
2. Steady Drip out of Faucet
3. Hot Water or Steam coming out of both the Faucet and the Vent Hole
4. Hot Water coming out of Faucet Vent Hole
5. Restricted Flow of Hot Water
6. Hot Water Drip out of Faucet
7. Dispenses Hot and Cold Water at the same time
8. No cold water available
9. Water does not dispense from unit
10. Cold Water dispenses from Faucet and Vent Outlet Simultaneously
11. Small amount of water periodically dispenses from faucet automatically
12. Dispense Buttons Stick
13. Run-On - Water continues to dispense out of faucet after releasing the dispense button

*This section also includes related instructions for Hot Tank Descaling*

## 1. Irregular / Intermittent Dispensing

Possible Reason	Solution
<p>Too much water pressure. Recommend 40 to 60 psi for <b>WL400 Water Treatment System</b> to operate properly.</p>	<p>Check water pressure at the inlet bulkhead with a water pressure gauge.</p> <p>Additional method of verification is to turn off water to unit and press the dispense button. Does the solenoid open without water pressure to the unit? Listen for solenoid to activate, not button “click”.</p> <p>Adjust water pressure to 40-60 psi.</p>
<p>Loose or bad connection on the Front Dispensing PCB or Solenoid Connector</p>	<p>Check that they are connected properly and tightened.</p>
<p>Solenoid</p>	<p>If both the Water Pressure and PCB have been ruled out, then it is the Solenoid.</p> <p>Replace Solenoid.</p>
<p>Dispensing button is broken on PCB</p>	<p>Check PCB for loose or damaged button. Replace PCB as necessary.</p>
<p>Mineral deposits on the expansion slot inside the Hot Tank vent chamber which blocks the normal path of water to expand.</p>	<p>Descale Hot Tank.</p> <p><b><u>See Hot Tank Descaling Instructions that are included further below in this Troubleshooting Section.</u></b></p>

## 2. Steady Drip Out of Faucet

Possible Reason	Solution
Debris in Solenoid	Inspect Solenoid for debris and clean out as needed.

## 3. Hot Water or Steam Coming out of both the Faucet and Vent Hole

Possible Reason	Solution
Improper tubing attachment from the hot tank to faucet or vice versa.	Check that the tubing is connected from tank outlets to correct faucet attachments. Connect tubing to outlets as needed.

## 4. Hot Water Coming out of Faucet Vent Hole

Possible Reason	Solution
Improper tubing attachment from the tank to faucet or vice versa.	Verify tubing is connected properly from tank outlets to correct faucet attachments.
Hot Tank outlet hole is scaled over.	<p>Inspect and Descale Tank as needed.</p> <p><b><u>See Hot Tank Descaling Instructions that are included further below in this Troubleshooting Section.</u></b></p> <p>See instructional video on the Partner Area of the Waterlogic.com website for more information.</p>
Expansion chamber is not sealed properly.	Replace the Hot Tank.

## 5. Restricted Flow of Hot Water

Possible Reason	Solution
Partially closed water supply valve to the unit.	Open water supply valve.
Hot Tank outlet hole is scaled over.	<p>Descalc Tank.</p> <p><b><u>See Hot Tank Descaling Instructions that are included further below in this Troubleshooting Section.</u></b></p> <p>See instructional video on the Partner Area of the Waterlogic.com website for more information. See instructional video on the Partner Area of the Waterlogic.com website for more information.</p>
Tubing is creased or has a “kink” in it.	Inspect and replace tubing as necessary.
Faucet nipple screen mesh has obstruction(s)	Unscrew faucet nipple from faucet and remove any obstruction(s) from screen mesh.
Exhausted Filter	Replace the Filter
Solenoid connection to the Display PCB	<p>Turn power off; unplug the unit and visually inspect solenoid connections into the Display PCB. Verify the soldering points on connections are secure into the board.</p> <p>Remove the PCB to inspect the front of the board.</p>
Solenoid Valve is Malfunctioning	Inspect valve components for proper function. Replace as necessary.

## 6. Hot Water Drip out of Faucet

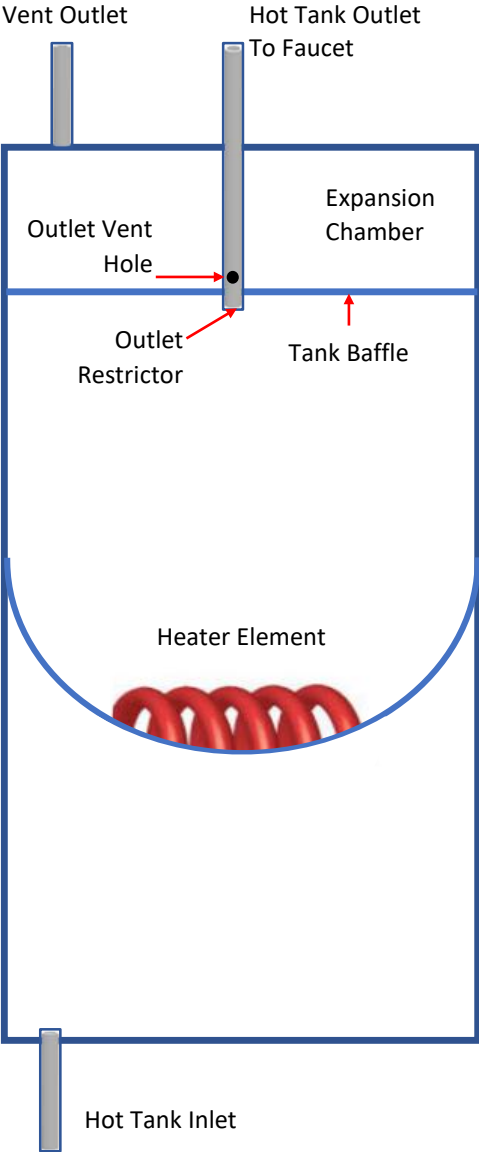
Possible Reason	Solution
<p>Small Outlet Vent Hole susceptible to scale build up.</p>	<p>Descale Tank.</p> <p><b><u>See Hot Tank Descaling Instructions that are included further below in this Troubleshooting Section.</u></b></p> <p>See instructional video on the Partner Area of the Waterlogic.com website for more information.</p>
	<p>All <b>Waterlogic</b> Hot Tanks have a built in Vent or Expansion Chamber in the top of the tank except for WL270 (GF) units.</p> <p>The Vent Chamber allows for expansion of the water when it is heated.</p> <p>The chambers are separated by a welded-in tank baffle.</p> <p>Water always flows into the bottom of the tank and out the top to the faucet.</p> <p>The hot tank outlet tube has a restrictor in its base. This ensures the reservoir is always full by allowing more water in than out.</p> <p>There is a small hole in the side of the tank outlet tube that allows air and water to pass into the vent chamber as it is heated.</p> <p>Water in the vent chamber is suctioned back through the outlet tube vent hole when water is dispensed.</p> <p>Expansion of water as it is heated in the reservoir will push the water out the faucet when the outlet tube vent hole becomes plugged with debris or scale.</p> <p>The small Outlet Vent Hole is susceptible to scale build up and is a key indicator that descaling is required.</p> <p>It is critical to descale the hot tank through the vent line and outlet line on a regular basis to prevent this problem.</p> <p>Descaling through the inlet and/or outlet lines only will not clean the vent chamber and outlet vent hole properly.</p>



## 7. Dispenses Hot and Cold Water at the Same Time

Possible Reason	Solution
Hot or Cold solenoid is stuck open.	<p>Remove Top cover.</p> <p>Check Hot Solenoid: Dispense cold water and visually inspect tubing for water flow from both tanks.</p> <p>Check Cold Solenoid: Disconnect elbow from outlet of cold solenoid. Select hot water and dispense (quickly releasing dispensing button to avoid much water coming out of cold solenoid).</p> <p>Replace solenoid as necessary.</p>

## 8. No Cold Water Available

Possible Reason	Solution
Closed Water Supply Valve	Open the Water Supply Valve
Cold Water Solenoid Valve malfunction	Inspect the valve components for proper functionality.
Green Heater and Compressor Switch on unit is off.	<p>Turn Green Heater and Compressor Switch on.  <i>I = ON</i></p> 
Loose connection(s) on the Display PCB	<p>Turn power off; unplug the unit and visually inspect solenoid connections into the Display PCB. Verify the soldering points on connections are secure into the board.</p> <p>Remove the PCB to inspect the front of the board.</p>
Exhausted Filter	Replace filters as needed.

## 9. Water does not dispense from Unit

Possible Reason	Solution
Closed water supply valve	Open the water supply valve.
The unit is not properly plugged into electrical outlet	Check electrical outlet connection, or for blown circuit breaker.
Green Heater and Compressor Switch button on unit is in the off position	Turn Green Heater / Compressor Switch on. <i>I = ON</i>
15 Amp Fuse Blown	Replace the 15 Amp Fuse as needed.
Water is present in the bottom tray, causing the leak detection to trigger.	Remove the top cover and front panel. Tip the unit slightly to drain, dry bottom tray completely.
Hot and Cold Solenoid connections into the Displace PCB are loose.	Turn power off; unplug the unit and visually inspect solenoid connections into the Display PCB. Verify the soldering points on connections are secure into the board.  Remove the PCB to inspect the front of the board.
Exhausted Filter	Replace filters as needed.



## **10. Cold Water Dispenses from Faucet and Vent Outlet Simultaneously**

<b>Possible Reason</b>	<b>Solution</b>
Improper tubing attachment from the tank to faucet or vice versa	Verify tubing is connected properly from tank outlets to correct faucet attachments.
Scale has formed inside cold tank outlet tube.	Remove cold water outlet tube from tank to faucet. Pour some scale remover into cold tank.
Expansion chamber in Cold Tank is not sealed properly.	Replace Cold Tank.

## **11. Small Amount of Water Periodically Dispenses from Faucet Automatically**

<b>Possible Reason</b>	<b>Solution</b>
Cold or Hot Water solenoid valve malfunction	Inspect valve components for proper function. Replace as necessary.
Obstruction in solenoid housing is preventing proper sealing of component.	Pre-determine whether water being dispensed is hot / cold. Isolate the water supply; push the DISPENSE button to release the line pressure, and remove the coil affixed to the solenoid stem.  Remove the stem from the solenoid housing and allow water from the tank to flush out the contaminant(s).

## **12. Dispense Buttons Stick**

<b>Possible Reason</b>	<b>Solution</b>
Dirt or Foreign material is filling the gap around the push-buttons.	Inspect the push buttons and clean surrounding area. Inspect faucet assembly inside the unit and clean as necessary.

### **13. Run On – Water continues to dispense out of faucet after releasing the dispense button**

#### **Reason**

“Run On” or “Carry On” is present in all Waterlogic pressure fed units without outlet solenoids.

“Run On” is defined is the amount of water that continues to dispense out of the faucet after releasing the dispense button.

Run On exists because the tanks pressurize as water is being dispensed. Every Waterlogic tank has an outlet restrictor to ensure the tanks remain full of water and water is controlled as it is released to the faucet. The inlet solenoid controls flow into the tanks. The tanks will “depressurize” once the dispense button is released the inlet solenoid closes. A small amount of water will “Run On” through the faucet as the tank depressurizes to atmospheric conditions.

Typical “Run On” is 2-3 seconds.

**“Run On” can be reduced by installing a pressure limiting device.**

The amount of inlet or supply pressure directly impacts the amount of “Run On” as quantified below.

WLCP Lab Testing of Run On 7-31-2013

Pressure	Pressure	Time	Flow Rate	Run On
Static PSI	Dynamic PSI	4 Liters	l/min	Seconds
68	40	61	2.9508197	3
50	30	72	2.5	2.5
32	20	92	1.956217	2
Pressure measured at inlet line to unit. Static with unit closed. Dynamic with unit dispensing cold water.				
No filters were installed in unit.				

## **HOT TANK DESCALING INSTRUCTIONS**

The hot tank requires removal of mineral deposits (descaling) on a regular basis. Typically descaling should take place every 6 to 12 months to preserve the long-term health of your unit.

Use non-toxic cleaner such as ScaleKleen, DEZCAL, 20% Citric Acid Solution, or Undiluted Vinegar Solution to remove mineral deposits as directed by the manufacturer depending upon filtration and local water conditions.

Descaling is an important process that removes calcium deposits, or scale, that can build up inside a tank over time. Calcium and scale is non-toxic but left unattended will hinder your unit's performance.

**⚠ WARNING!** ***PERSONAL PROTECTIVE EQUIPMENT REQUIRED.** Always ensure proper ventilation and use rubber or nitrile gloves and eye protection when using chemicals. Refer to Material Safety Data Sheet for specific requirements of each product.*

**⚠ CAUTION!** ***STAINLESS STEEL TANK DESCALING.***

*The hot tank is made from stainless steel. Ensure descaling solution is compatible with stainless and always flush the unit completely. Dispose in an environmentally safe manner.*

### **Materials Needed:**

- Personal Protective Equipment. Rubber or Nitrile Safety Gloves and Protective Eyewear
  - Phillips Screwdriver
  - Temperature Gauge
  - Water Pitcher or Container to collect water from the faucet
  - 5-gallon container or drain basin
  - Citric Acid Based Cleaner
  - ¼" Plastic Tubing, at least 4 feet in length, and assorted ¼" quick connect fittings
  - Sanitizing Cartridge
  - Food Coloring
9. Put descaler per directions and 3 drops of food coloring into the descaling cartridge.
  10. Connect descaling cartridge to the inlet water supply and connect to inlet bulkhead fitting on the back of the unit. Turn on Water Supply.
  11. Select Hot Water and depress the Main Dispensing Button on the Front Control Panel until descaling solution (colored water) comes out of the faucet. Container and drain basin will be required to catch water from the faucet.
  12. Turn off water supply and remove sanitizing cartridge from inlet water supply. Reconnect water supply to inlet fitting.

13. Allow descaling solution to remain in the Hot Tank for 15 minutes (length of time may vary depending on water conditions).
14. Place a pitcher, catch basin or other container under the faucet of the **WL400 Water Treatment System**.
15. Flush the Hot Tank until water runs clear.
16. Once clear water dispenses from the faucet the Hot Tank has been descaled. Always ensure unit is performing to the customer's satisfaction.

**⚠ WARNING! HOT WATER HAZARD.** *WL400 Water Treatment System produces VERY HOT WATER up to 203°F (95°C). Water above 125°F (52°C) can cause severe burns or scalding. Hot water should be dispensed carefully into insulated container to avoid injury.*

**⚠ CAUTION! MUST REPLACE HOT TANK 3-5 YEARS DEPENDING ON USAGE.** *The hot tank and its controls must be replaced a minimum of every five years to ensure efficient and dependable operation.*

**⚠ WARNING! REINSTALL ALL PANELS AND COVERS.** *Always reinstall all panels, protective covers, and fasteners after servicing equipment. Failure to do so could result in severe personal injury and will void the certifications and warranty of the equipment.*

## COLD WATER TROUBLESHOOTING INDEX

### 1. Cold Water is not Cold (41° +/- 5° F)

#### 1. Cold Water is not Cold (41° +/- 5° F)

Possible Reason	Solution
No power or refrigeration elements	<p>Check that the Green Heater/Compressor switch is on. / = ON</p> 
Tank has run out of cold water.	<p>Wait for cold tank to chill water to temperature prior to dispensing more cold water.</p> <p>A greater capacity of <b>Waterlogic</b> Water System is available.</p>
Cold Water Thermostat	Check continuity of thermostat with multimeter. Replace thermostat as required.
Refrigerant has run out	Run compressor for at least ten minutes. If condenser is not warm, then refill the refrigerant.
Compressor problem	If compressor is not running, repair or replacement is needed.

## HOT WATER TROUBLESHOOTING INDEX

### Hot Water Problems

1. Hot Water is not Hot 185° +/- 5°
2. Boiling of the Hot Tank at higher elevations

Also includes related instructions for



- *Disabling Sleep Mode*
- *Resetting the Hot Tank Overloads or High Limit Safety*

### **1. Hot Water is not Hot (185° +/- 5° F)**

The Hot temperature set point is 185° and is controlled by a thermostat on the side of the tank.

There are two resettable overloads or high limit safety above the thermostat on the side of the tank that will trip to prevent damage to the unit if the tank is dry heated (turned on without water in it).

It typically takes 10 minutes for the 500W to heat the 1.2 Liter of room temperature (ambient) water to the 185°F set point.

Possible Reason	Solution
Is unit in sleep mode?	<p>If no water has been dispensed for 3 or more hours, unit goes into sleep mode. Dispense hot water, wait 5 minutes, check temperature.</p> <p>If unit still does not heat proceed to “No power to heater elements” below.</p> <p><b><u>See Disabling Sleep Mode Instructions that are included further below in this Troubleshooting Section</u></b></p>
No power to heater elements	<p>Check that the Green Heater / Compressor switch is on. <i>I = ON</i></p> <div style="text-align: right;">   </div>
Loose or improperly connected wire(s) to the heating element / hot tank.	<p>Visually inspect wire leads going to the hot tank; confirm proper connections to the heating elements.</p> <p>Hot tank life is 3-5 years, depending on usage.</p> <p><i>*Typically, dealers swap out the hot tank at site, take back to the shop to repair.</i></p>



<p>Overloads Tripped</p> <p><i>Overloads are a safety feature to ensure the tank does not overheat.</i></p>	<p>Overloads will “click” when pushed. The overload is automatically reset when pressed.</p> <p><b><u>See Resetting the Hot Tank Overloads or High Safety Limit Instructions that are included further below in this Troubleshooting Section</u></b></p>
<p>Thermostat or overloads “open” on Hot Tank</p>	<p>Turn Power off. Check OHM’s resistance across terminals on each Thermostat and Overloads separately.</p> <p>Good components will indicate a closed circuit or zero OHM’s on the meter.</p> <p>Replace components as necessary.</p>
<p>Heating Coil not Working</p>	<p>Turn Power off</p> <p>Drain hot tank</p> <p>Use multi-meter to check heater element for approximately 26 OHM’s resistance.</p> <p>Hot tank must be empty if you are checking for continuity.</p> <p>Replace Hot Tank as necessary.</p>

## 2. Boiling of the Hot Tank at higher elevations

The **WL400** Water Treatment System has an extra hot temperature reset preset to 95°C (203°F). This leads to boiling of the Hot Tank at higher elevations. There are two options to correcting this issue.

**Option 1** - Replace Main PCB Part Number EN-6137 (Waterlogic Spare parts have a lower 90°C (194°F) Extra Hot Setting).

**Option 2** - Turn down the temperature calibration on the Main PCB Part Number EN-6137.

1. Remove Left Hand Side Panel

2. Remove the Main PCB Metal Cover

3. Access and locate the Hot Temperature Calibration Trimmer (potentiometer) on the Main PCB



4. Turn the Hot temperature calibration counterclockwise from 12:00 position to 11:00 position

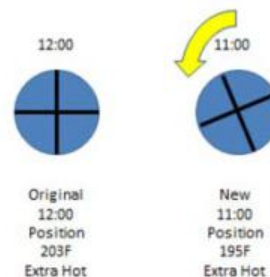





5. Check the output temperature of both the Hot and Extra Hot. Extra Hot should be approximately 87.8 – 90.6 °C (190 -195°F) at the faucet.

## DISABLING SLEEP MODE



Sleep Mode - press any button to bring machine out of sleep mode

## RESETTING THE HOT TANK OVERLOADS OR HIGH LIMIT SAFETY

1.	Turn off Green Heater/Compressor Switch on rear of unit. <i>O=OFF</i>	
2.	Unplug the Power Cord from rear of unit.	
3.	Remove the Tower Cover Locking Screws and Slide Locks towards outside of unit to unlock both locks.	
4.	Slide Top Cover forward and lift in front of top cover to open.	
5.	Remove the 2 Phillips Screws from Left Side Panel (when standing behind unit) and remove side panel.	
6.	Check and press both Thermal Overload buttons on Hot Tank.	
7.	Close, lock and replace Top Cover Screws	
8.	Turn on Red Power Switch and Green Heater / Compressor Switch. <i>I=ON</i>	