

HOT WATER TROUBLESHOOTING INDEX

1. Hot Water is not Hot 85°C ± -15°C (185° ± 5° F)

Also includes related instructions for:

- *Programming - Disabling Energy Saving Sleep Mode*
- *Resetting the Hot Tank Overload or High Limit Safety*
- *Programming - Changing Hot Water Mode to Ambient Water*

1. Hot Water is not Hot 85°C ± -15°C (185° ± 5° F)

The Hot Temperature set point is 85°C (185°F) and is controlled by a thermostat on the side of the Hot Tank.

There is a resettable overload or high limit safety above the thermostat on the side of the Hot Tank that will trip to prevent damage to the unit if the tank is dry heated (turned on without water in it).

The **WL100 Water Treatment System** is programmable to make Cold / Ambient water – refer to Disabling Sleep Mode instructions included further below in this Troubleshooting Section.

The **WL100 Water Treatment System** does NOT have Extra Hot capability and the maximum hot temperature is 87°C (189°F).

It typically takes 10 minutes for the 500W to heat the 1.6 Liter (0.4 Gallon) of room temperature (ambient) water to the 85°C (185°F) set point.

Possible Reason	Solution
No power to Heater elements	<p>Check that the Red Heater and Compressor switch is on.</p> <p>Turn Red Heater and Compressor Switch on. <i>I = ON</i></p> 
Is unit in sleep mode?	<p>If no water has been dispensed for 3 or more hours, unit goes into sleep mode. Dispense hot water, wait 5 minutes, check temperature.</p> <p>If unit still does not heat proceed to “No power to Heater elements” below.</p> <p><u>If unit does heat but you would like to Disable Sleep Mode, refer to the instructions included further below in this Troubleshooting Section</u></p>

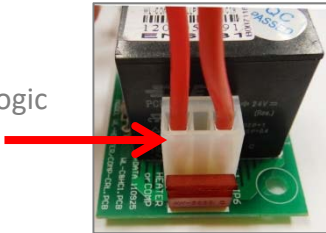
<p>Hot Tank Overload Tripped</p> <p><i>Overload is a safety feature to ensure the tank does not overheat.</i></p>	<p>Overload will “click” when pushed. The overload is automatically reset when pressed.</p> <p><u>See Resetting the Hot Tank Overload or High Limit Safety Instructions that are included further below in this Troubleshooting Section</u></p>
<p>Energy Saver PCB Relay Board Connector Bad</p>	<p>Inspect connector for discoloration. If there is no discoloration, contact Waterlogic Technical Department.</p> 
<p>Thermostat or overload “open” on Hot Tank</p>	<p>Turn Power off. Check OHM’s resistance across terminals on each Thermostat and Overload separately.</p> <p>Good components will indicate a closed circuit or zero OHM’s on the meter.</p> <p>Replace components as necessary.</p>
<p>Loose or improperly connected wire(s) to the heating element / Hot Tank.</p>	<p>Visually inspect wire leads going to the Hot Tank; confirm proper connections to the heating elements.</p> <p>Hot Tank life is 3-5 years depending on usage, depending on usage.</p> <p><i>*Typically, dealers swap out the Hot Tank at site, take back to the shop to repair.</i></p>
<p>Heating Coil Not Working</p>	<p>Turn Power off; Drain Hot Tank; Use multi-meter to check Heater element for approximately 26 OHM’s resistance.</p> <p>Hot Tank must be empty if you are checking for continuity.</p> <p>Replace Hot Tank as necessary.</p>
<p>Improper Jumper Settings</p>	<p>The unit has been changed to a cold/ambient setting (JP9 has been moved from Pin 1 and Pin 2).</p> <p>Verify that Jumper Pins are located properly for Hot Water Option.</p> <p><u>See Changing Hot Water Mode to Ambient Water Instructions included further below in this Troubleshooting Section</u></p>

PROGRAMMING “DISABLING ENERGY SAVING SLEEP MODE”

All **WL100 Water Treatment Systems** come from the factory with Energy Saving Sleep Mode engaged to meet the Energy Star Certification requirements. Energy Star Sleep Mode disables the Heater Circuit if the hot dispense has not been used for 3 hours.



Selecting any button "wakes up" the **WL100 Water Treatment System** and turns the Heater circuit back on. The Hot Tank will typically take less than 10 minutes to heat the water from ambient to the 85°C (185°F) set point.

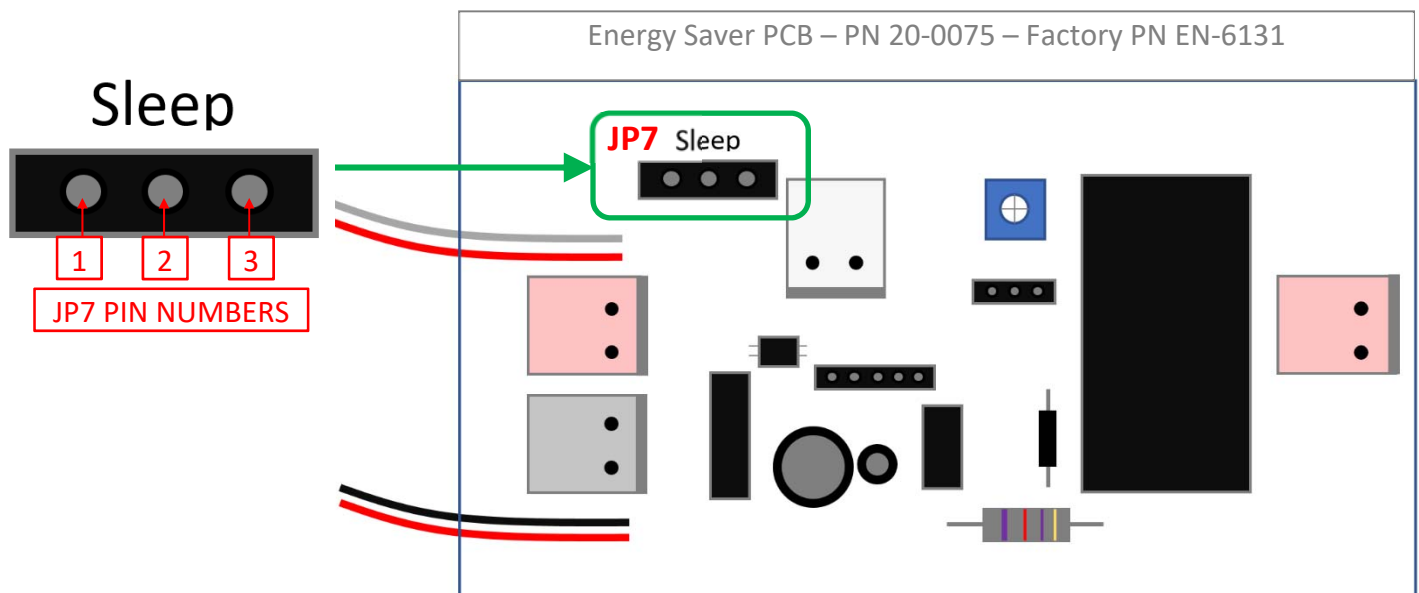

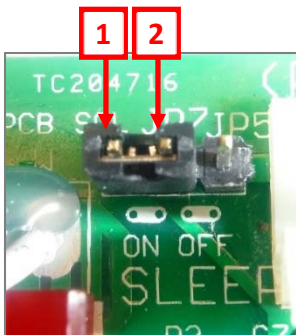
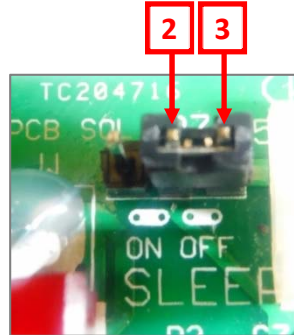

Unplug Power Cord and remove Top Cover to access Energy Saver PCB.

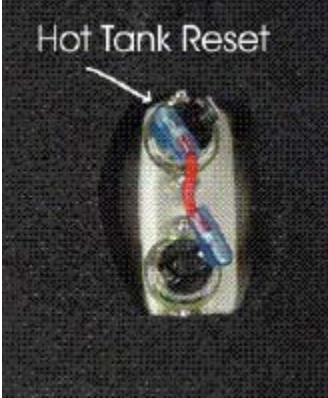

ENERGY SAVING SLEEP MODE	
ON	OFF
PCB Jumper JP7 (Pin Numbers 1 and 2) 	PCB Jumper JP7 (Pin Numbers 2 and 3) 

RESETTING THE HOT TANK OVERLOAD OR HIGH LIMIT SAFETY

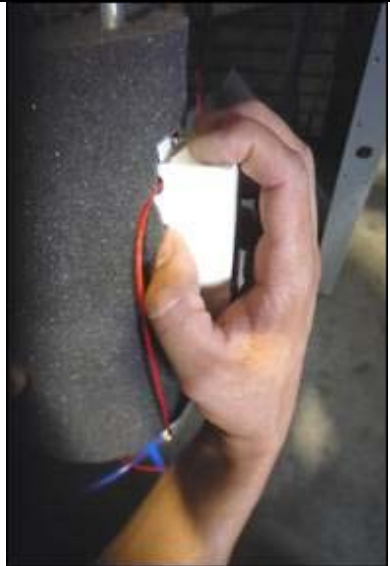
1.	Red Compressor/Heater Switch must be in the <i>O=OFF</i> position	
2.	Unplug the Power Cord from rear of unit.	
3.	Remove the Lower Front Panel of unit by removing the Phillips head screws underneath the Lower Front Panel.	
4.	Locate the Protective Metal Box on the rear of the Hot Tank. As you look through the Condenser coils on the rear of the unit, you will see the Hot Tank located on the right-hand side.	
5.	<p>From the front of the WL100 Water Treatment System, reach up behind the Hot Tank and take hold of the Protective Metal Box covering the Thermostat and overload on the Hot Tank.</p> <p>There are nuts that secure the Protective Metal Box to the Hot Tank, are loose enough to allow you to remove the Protective Metal Box.</p> <p>If the nuts on the metal box are too tight, loosen the nuts securing the Hot Tank to the Upper Base of the WL100 Water Treatment System unit and lower the Hot Tank so you can remove the Protective Metal Box.</p>	

<p>6.</p>	<p><i>For demonstrative purposes, photos below have lowered the Hot Tank from the unit.</i></p> <p>Press the reset button</p>	 
<p>7.</p>	<p>Reattach the Protective Metal Box by depressing the top flap of the Protective Metal Box so it snaps back into its original position on the Hot Tank.</p>	
<p>8.</p>	<p>Replace the Lower Front Panel.</p>	
<p>9.</p>	<p>Plug in the Power Cord.</p>	
<p>10.</p>	<p>Turn on the Red Compressor/Heater Switch <i>I=ON</i> position</p> <p>The Hot and Cold Tanks must be filled with water BEFORE turning on the Red Heater and Compressor Switch.</p>	
<p>11.</p>	<p>Verify the cooler is fully operational before installing it at the customers' site.</p>	

PROGRAMMING “CHANGING HOT WATER MODE TO AMBIENT WATER”

The **WL100 Water Treatment System** comes with set to Hot / Cold, which can be changed to Ambient / Cold settings. On the Energy Saver PCB, move the Jumper on JP9 from Pins 1 and 2 to Pins 2 and 3.

Unplug Power Cord and remove Top Cover to access Energy Saver PCB.

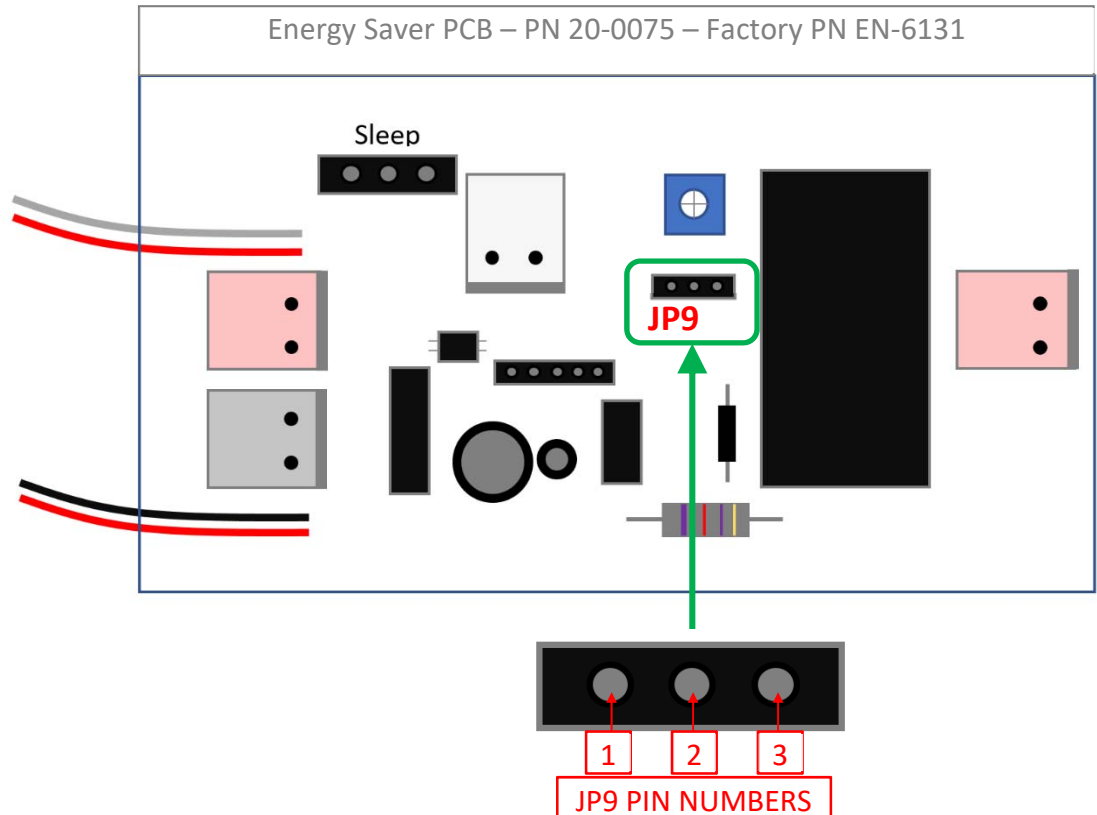

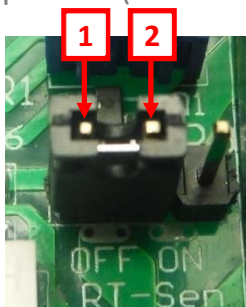
Hot and Cold (Factory Settings)	Ambient and Cold
PCB Jumper JP9 (Pin Numbers 1 and 2) 	PCB Jumper JP9 (Pin Numbers 2 and 3) 