



WL800 – MAX II

MANUAL



Waterlogic Commercial Products, LLC
3175 Bass Pro Drive
Grapevine, TX 76051
(800) 288-1891 www.waterlogicdealers.com
Tech Portal Website: techportal.waterlogic.com

WL800 MANUAL

Congratulations on your choice of the **Waterlogic WL800 Water Treatment System**. The **WL800 Water Treatment System** is a fully programmable self-contained model that dispenses cold and hot water. Every **WL800 Water Treatment System** includes:



High Performance Multi-Stage Filtration



Recirculating Ultraviolet (UV) Purification

The **Waterlogic WL800 Water Treatment System** provides exceptional quality and great tasting water with every use.

TABLE OF CONTENTS

- Features and Benefits.....3
- Certifications4
- Introduction.....5
- Safety Alert Symbols.....5
- Safety Precautions.....6
- Model and Part Designations7
- Specifications.....7
- Operating Instructions.....8
- Control Panel Instructions9
- Flow Diagram.....10
- Disassembling and Refitting Instructions11
- Pre-Installation Instructions33
- Draining Instructions36
- Installation Instructions.....38
- Service Requirements.....40
- Replacement Components41
- Hot Tank Descaling Instructions.....42
- Drawing and Parts List.....44
- Electrical Drawings51
- Cable Specifications.....52
- Circuit Diagrams55
- PBA Location Diagrams58
- Fault Codes63
- Troubleshooting65
- Warranty74



WL800 FEATURES AND BENEFITS

Cold and Hot Water

Cold and Hot Water Selections to meet your customers' demands.

High Volume Storage and Water Capacity

16 liters of Cold Water Tank Capacity and 3.5 liters of Hot Tank Capacity

Large Dispense Area

11.7 inch dispense height, ideal for filling large jogs and carafes

Child Safeguard

Hot Water safety feature to protect against accidental usage.

4-Step Filtration System

The *Waterlogic WL800 Water Treatment System* uses a 4-stage reverse osmosis (RO) to product the best quality drinking water. It includes a sediment filter, pre-carbon filter, reverse osmosis membrane and a post carbon filters. These filters remove impurities and improve taste.

UV Sanitation

Re-circulating UV systems sanitizes the water by reducing bacterial growth giving a reassurance of fresh clean drinking water.

WL800 CERTIFICATIONS

Waterlogic Water Treatment Systems have been tested, and certified to rigorous NSF and UL Standards. We believe that performance testing and certifications validate *Waterlogic* as a world-leader in water treatment systems.

WL800 Certifications Include



UL399 – Standard for Drinking Water Cooler

Underwriters Laboratories (UL) Certified the *WL800 Water Treatment System* to ANSI/UL 399 Standard for Drinking Water Coolers.



NSF / ANSI-42 – Drinking Water Treatment Units – Aesthetics Effects

NSF / ANSI 53 – Drinking Water Treatment Units – Health Effects

NSF / ANSI 58 – Reverse Osmosis Drinking Water Treatment Systems

This System has been tested and certified in accordance with NSF/ANSI-42 – Drinking Water Treatment Units – Aesthetics Effects, NSF / ANSI 53 – Drinking Water Treatment Units – Health Effects, and NSF / ANSI 58 – Reverse Osmosis Drinking Water Treatment Systems by the Water Quality Association (WQA).



BPA Free - *Waterlogic* tests for BPA and declares that all of its products are Bisphenol-A FREE and contain no harmful BPA plastics.

Waterlogic is certified to ISO 9001:2015 – Quality Management Systems (certified by Intertek). ISO 9001 is the internationally accepted standard for well managed organizations that have adopted the key quality management principles to its operations to bring consistent quality products and a culture of continuous improvement.



Safe Drinking Water Act

Waterlogic water treatment systems conform to the Safe Drinking Water Act (SWDA) “lead-free” amendment effective January 4, 2014.

INTRODUCTION

Carefully read and follow all instructions to ensure proper and efficient operation of your **Waterlogic WL800 Water Treatment System**. Contact **Waterlogic** or an **Authorized Waterlogic Dealer** if you have any questions.

Waterlogic and **Authorized Waterlogic Dealers** employ trained service personnel who are experienced in the installation, function and repair of **Waterlogic** equipment. This publication is written for use by these qualified individuals. **Waterlogic** encourages users to learn about products, however, we believe that product knowledge and service is best obtained by consulting **Waterlogic** or an **Authorized Waterlogic Dealer**.

Waterlogic water treatment systems should be combined with selected water treatment components to create a system specifically tailored for each application by trained and qualified personnel.

Products manufactured and marketed by **Waterlogic** and its affiliates are protected by patents issued or pending in the United States and other countries.

Waterlogic reserves the right to change the specifications referred to in this literature at any time, without prior notice. Changes or modifications not expressly approved by **Waterlogic** could void the warranty and user's authority to operate the equipment.

SAFETY ALERT SYMBOLS

Read and follow all safety information carefully. The signal words used in this manual are selected as shown below and based on an assessment of the degree of potential injury or damage (severe or minor) and the occurrence of injury (definitely occurs or has the potential to occur) when the warning is ignored:

 **DANGER!**

Indicates a situation which, when not avoided, results in death or severe injury.

 **WARNING!**

Indicates a situation which, when not avoided, has the potential to result in death or severe injury; and/or severe property damage.

 **CAUTION!**

Indicates a situation which, when not avoided, results or has the potential to result in minor injury; and/or minor property damage.

SAFETY PRECAUTIONS

Basic safety precautions should be followed, including the following:

- ⚠ DANGER!** *If incorrectly installed, operated or maintained, this product can cause death or severe injury. Those who install, operate, or maintain this product should be trained in its proper use, warned of its dangers, and should read the entire manual before attempting to install, operate, or maintain this product.*
- ⚠ WARNING!** *Unit is to be used for its intended purpose as described in this manual, and untrained individuals who use this manual assume the risk of any resulting property damage or personal injury.*
- ⚠ WARNING!** **HOT WATER.** *Unit produces Very Hot Water up to 203°F. Water above 125°F can cause severe burns or scalding. Keep unauthorized people and children away from the unit to avoid accidental dispensing of hot water. Children should not use without supervision.*
- ⚠ DANGER!** **ELECTRICAL SHOCK HAZARD.** *Always unplug from power supply prior to servicing equipment to prevent electrical shock.*
- ⚠ WARNING!** *This system to be used for water only and is not intended for use where water is microbiologically unsafe or with water of unknown quality without adequate disinfection before or after the system. The system is designed for the supplemental bactericidal treatment of either treated and disinfected public drinking water, or other drinking water, which has been tested and deemed acceptable for human consumption by the state or local health agency having jurisdiction. The system is designed to reduce normally occurring non-pathogenic or nuisance microorganisms only. System is not intended for treatment of contaminated water.*
- ⚠ WARNING!** **Dispenser Could Tip or Fall causing serious injury.** *Always install unit on a firm, flat, and level surface and secure the **WL800 Water Treatment System** to the base cabinet with the screw provided to lock the components together. Never place heavy items on top of unit and never climb, stand, or hang on unit or storage cabinet to prevent injury and damage.*
- ⚠ CAUTION!** **INDOOR USE ONLY.** *Do not install outdoors or where unit is in direct sunlight. Do not install where ambient temperature goes below 50 °F or above 97 °F. Avoid high humidity and moisture. Product life and performance will be impacted and warranty could be voided.*

MODEL/PART DESIGNATIONS

BRAND NAME	DESCRIPTION	MODEL – PART NUMBER
<i>WL800</i>	Waterlogic WL800 – Cold and Hot	16-MAXH2

SPECIFICATIONS

<u>ITEM</u>	<u>WL800</u>
Water Connection	¼" Quick Connect
Cold Water Temperature	Cold Water Temperature – Factory Set Point 5°C (41°F)
Hot Water Temperature	70 - 95°C (158-203°F) Programmable
Recommended Service Pressure	40-60 psi (275-414 kPa) – Use Pressure Regulator
Maximum Working Pressure	60 psi (414 kPa) – Use Pressure Regulator
Environmental Temperature	2 - 37°C (35-100°F)
Refrigerant Gas	R134a – 2.05 oz. (65 grams) - Hi (290 psi) Low (90 psi)
R134a Pressures	High (290 psi), Low (90 psi)
RO Output	284 Liters per day (75 Gallons per Day)

SHIPPING SPECIFICATIONS

<u>ITEM</u>	<u>DIMENSIONS</u>
Width/Depth/Height	445 mm (17.5 inches) x 508mm (20 inches) x 1257mm (49.5)
Weight – Dry (w/o packaging)	42 kg (93 lb.)
Shipping Information (length x width x height)	546.1 mm (21.5 inches) x 635 mm (25 inches) x 1321 (52 inches) 4 units per pallet
Shipping Weight – Dry	46 kg (103 lb.)

ELECTRICAL SPECIFICATIONS

15 Amp Service⁺
AMP DRAW (approximate) = 6.5 Amps

OPERATING INSTRUCTIONS

Dispensing Water

Cold Water Selection

Push the cup-touch

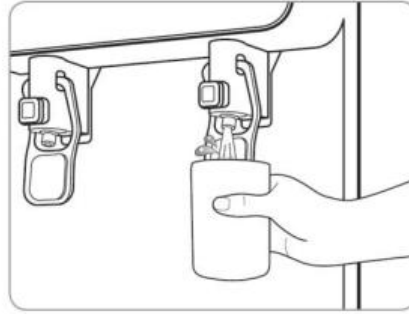

Hot Water Selection

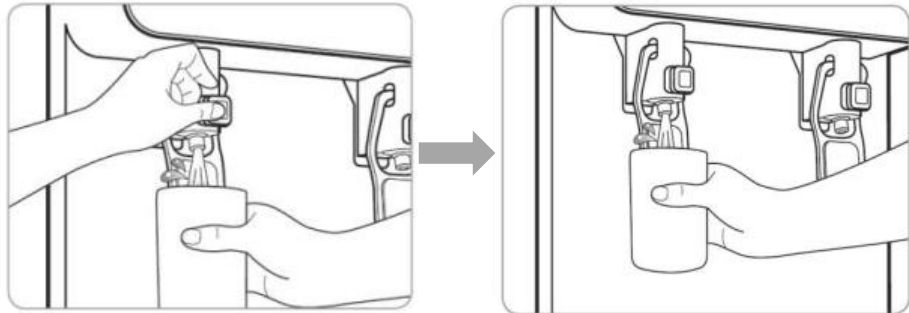

Press the Hot Water Safety Button and push the cup touch lever.

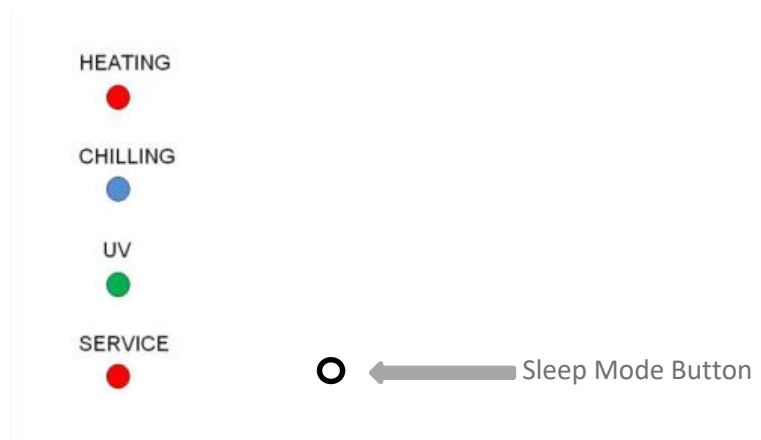

CONTROL PANEL INSTRUCTIONS

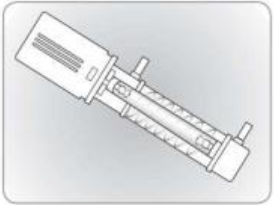

The above shows front LCD display and control panel for the **Waterlogic WL800 Water Treatment System**.

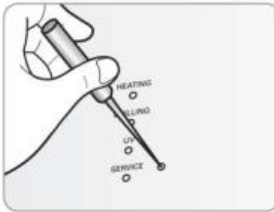
Button	Operational Use	
Heating	LED is on when heater is working	
Chilling	LED is on when cooling system is working	
UV	LED is on when UV sterilization light is on. UV sterilization has UV light inside. Water runs through UV sterilization filter and UV light sterilizes the water. UV light is on when nobody uses the device for more than an hour. UV indicator is on when UV light is on. The UV recirculating system starts when the WL800 Water Treatment System is idle and unused for one hour. The UV system will operator for 1 hour every 4 hours that the WL800 Water Treatment System is idle. (1 hour ON, 3 hours OFF).	
Service	LED is on when a water leak is detected. Contact your Service Center as soon as you find the Service LED on.	
Sleep Mode Button	Sleep mode is defaulted to OFF. If you would like to place the WL800 Water Treatment System into sleep mode manually, depress the sleep Mode Button. After 72 hours, if the WL800 remains idle and unused, the unit will enter sleep mode. To awaken the WL800 from sleep mode, you will need to dispense 20 ounces of water from the machine (hot or cold) which will start the Hot Tank heater.	

WL800 FLOW DIAGRAM

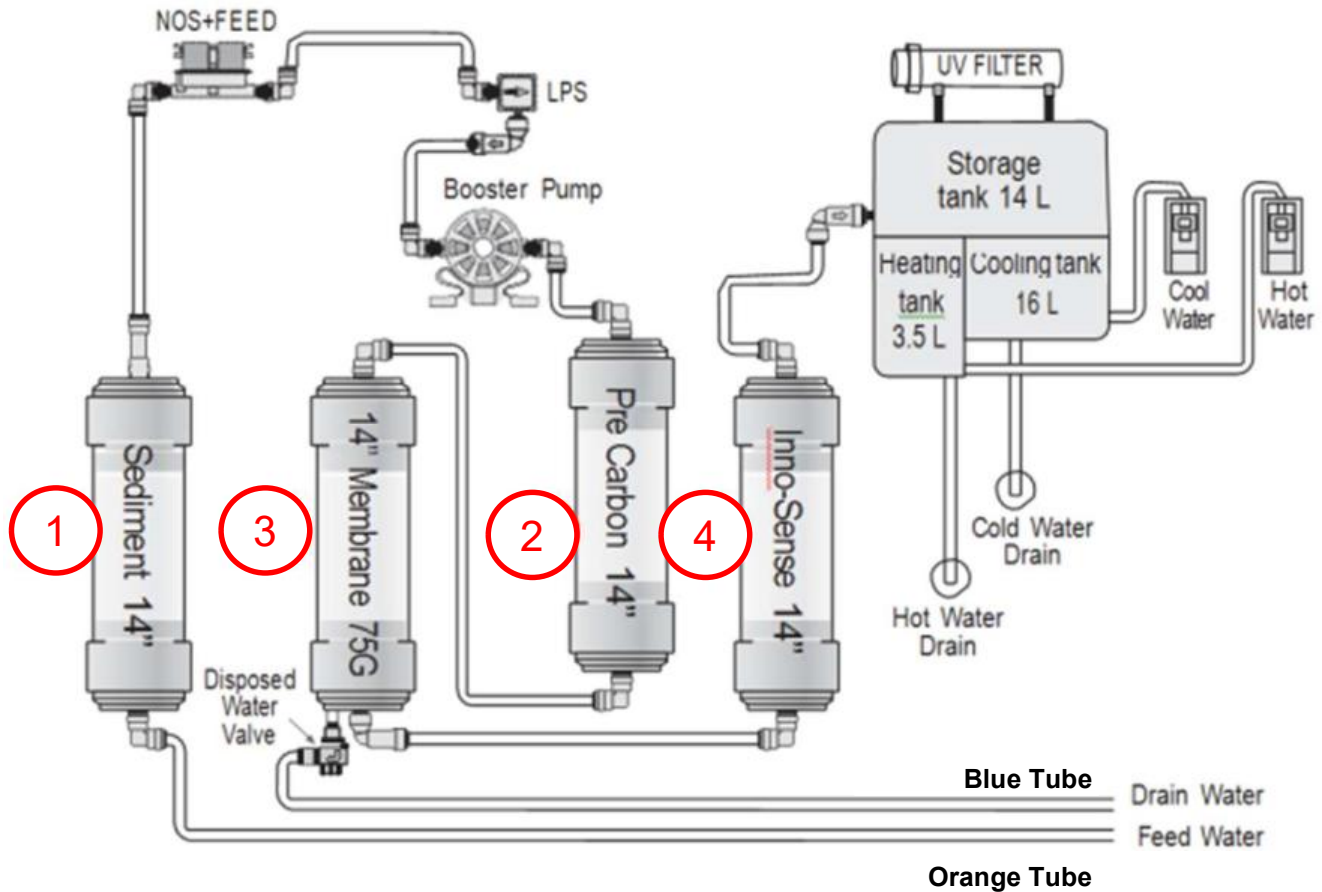

The **Waterlogic WL800 Water Treatment System** is a 4-step Water Filtration system

Step 1: PLUS SEDIMENT FILTER (*WLCP Part Number 16-1000*). This plus sediment filter has the functions to reduce sediment (rust, dirt, sand) from feed water and to protect membrane and pre-carbon filter from being plugged.

Step 2: PRE-CARBON FILTER (*WLCP Part Number 16-1001*). This Pre-Carbon filter reduces aesthetic chlorine, odor, volatile organic compounds (VOC's).

Step 3: RO MEMBRANE FILTER (*WLCP Part Number 16-0002*). RO Membrane Filter reduces water contaminants such as pentavalent arsenic, barium, cadmium, selenium, radium 226/228, trivalent chromium, hexavalent chromium, lead, and nitrate/nitrite. RO Membrane Filter produces 75 Gallons per day.

Step 4: INNO-SENSE FILTER (*WLCP Part Number 16-1003*). This Inno-sense filter improves taste of the product water

DISASSEMBLING AND REFITTING INSTRUCTIONS

Exercise Caution not to damage or deform any parts when disassembling the system.

Refit the system in the reverse order of disassembling.

Before disassembling the WL800 Water Treatment System

1. Block the main water by closing the main water supply valve.
2. Completely drain the water from the water tank.
 If the water is splashed during the repair, insulation may deteriorate, resulting in danger.
3. Unplug the **WL800 Water Treatment System**.
4. When disassembling and refitting the unit with its side touching the ground, perform the job on a working cloth. *Without the working cloth, the product may get scratches.*

Tools Needed:

- Phillips Screwdriver
- Flathead Screwdriver
- Needle Nose Pliers

REMOVING TOP COVER ASSEMBLY

1. Remove Top Cover Assembly in direction shown



2. Remove Silicone Overheating Hose



3. Remove the nine clips on the Cap-Main Tank Assembly



4. Remove Cap-Main Tank Assembly in direction shown



5. Remove the Ceramic Filter in the direction shown



6. Remove Separator Board in direction shown



7. Remove Connector-Cold Water Extraction in direction shown

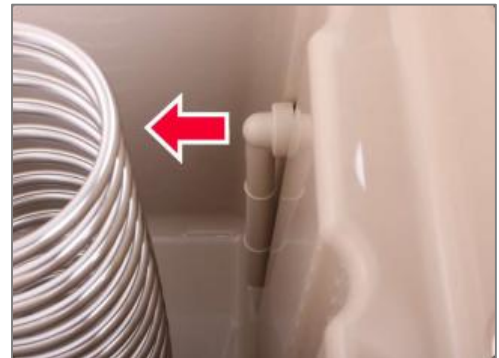

REMOVING FRONT COVER LOWER ASSEMBLY

1. Remove Drip Tray Grill in direction shown



2. Detach the Grill Tray Assembly as shown



3. Remove the screw (THT 4X10) located on the Front Cover Lower Assembly as shown.



4. Press down on the Front Cover Lower Assembly and remove in the direction shown



REMOVING UPPER COVER LOWER ASSEMBLY

1. Remove the two screws (THT 4X10) from the Front Cover Upper Assembly

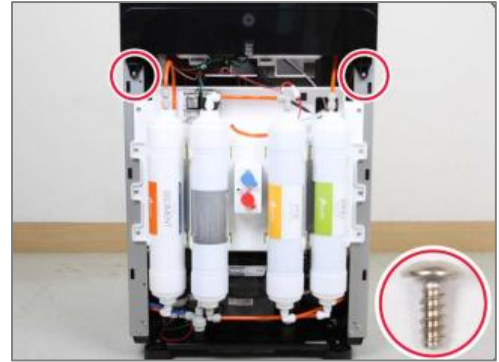

2. Remove the two screws (THT 4X10) from the Front Cover Upper Assembly

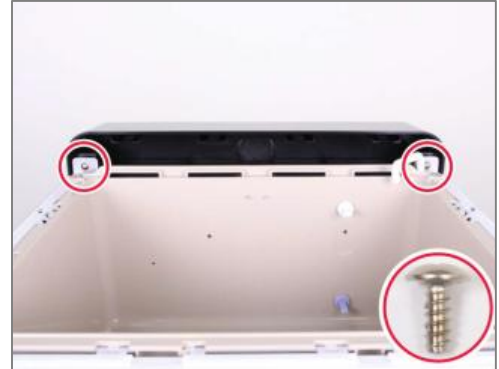

3. Lift up the Dispensing Handles



4. Lift the Front Cover Upper Assembly and remove in direction shown

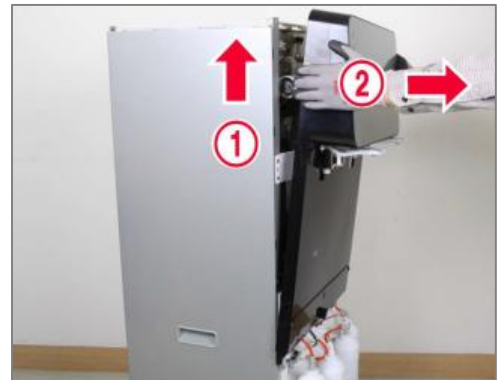

5. Remove the connector from PBA Cover Front Assembly



6. Remove the two screws (THT 4X12) from PBA Cover Front Assembly



7. Remove the two screws (THT 4X8) from PBA Front Assembly

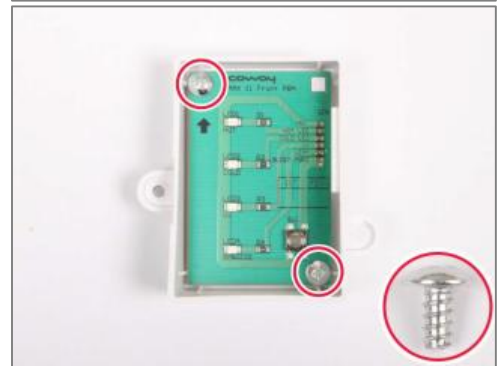

DISASSEMBLING FAUCET ASSEMBLY

HOT WATER FAUCET SAFETY ASSEMBLY

1. Remove the two THT 4x10 screws from the Hot Water Faucet Safety Assembly

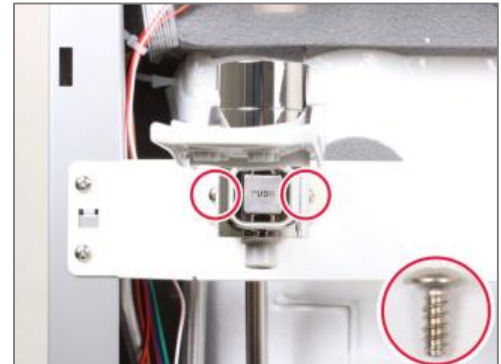

2. With a flathead screwdriver, remove the hose connected to the Hot Water Faucet Safety Assembly

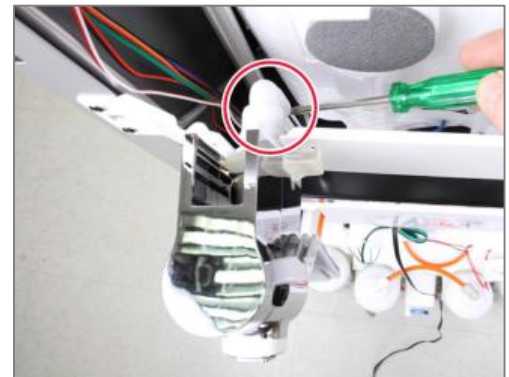

COLD WATER FAUCET ASSEMBLY

1. Remove the two THT 4x10 screws from the Cold Water Faucet Assembly

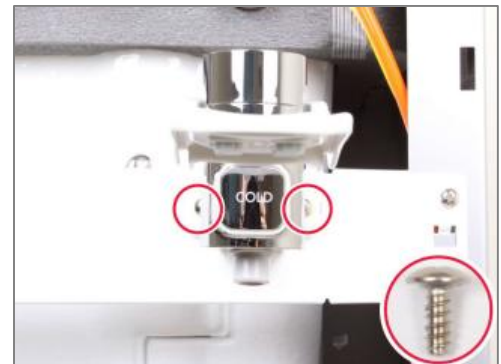

2. With a flathead screwdriver, remove the hose connected to the Cold Water Faucet Assembly

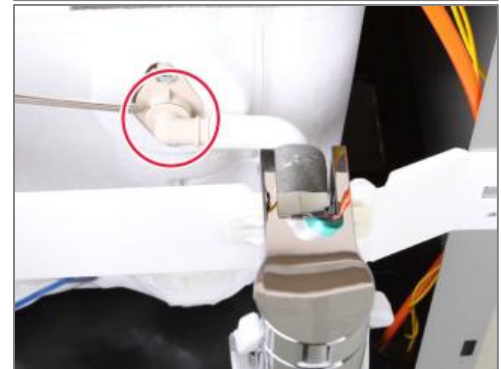

FAUCET BRACKET

1. Remove the four THT 4x10 screws from the Faucet Bracket

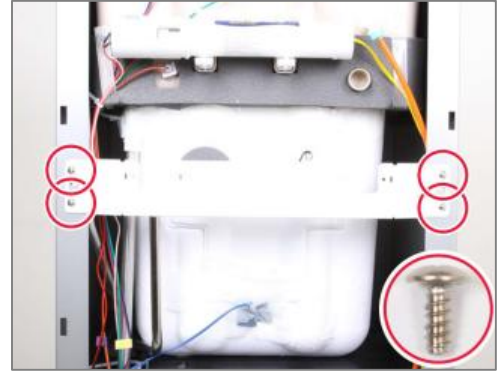

DISASSEMBLING PBA ASSEMBLY

PBA MAIN ASSEMBLY

1. Press down on hooks to remove the PBA Cover
2. Remove all connectors from the PBA Assembly
3. Remove the two screws THT 4x8 on the PBA Main Assembly

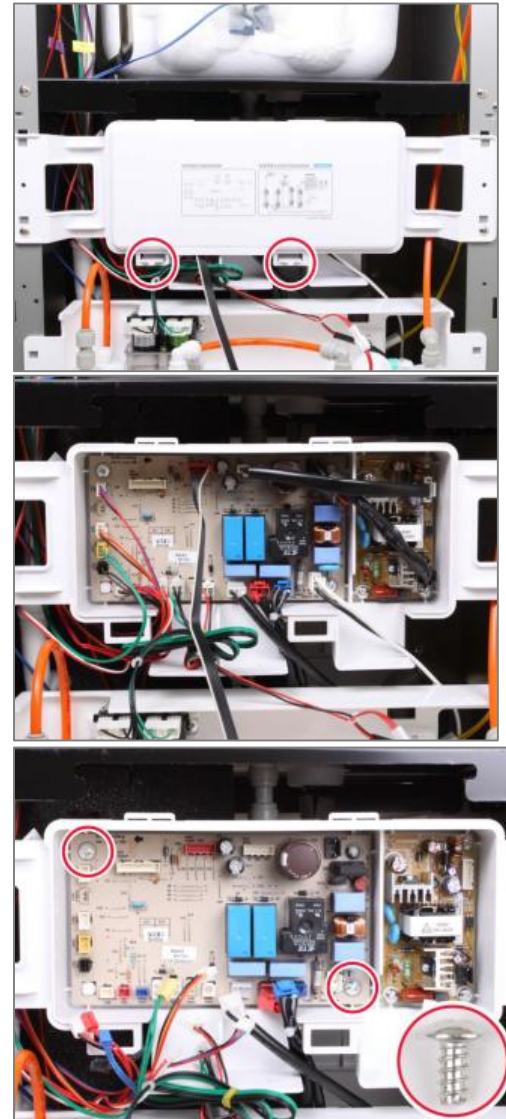

PBA SMPS

1. Remove the three screws THT 4x8 on the PBA SMPS

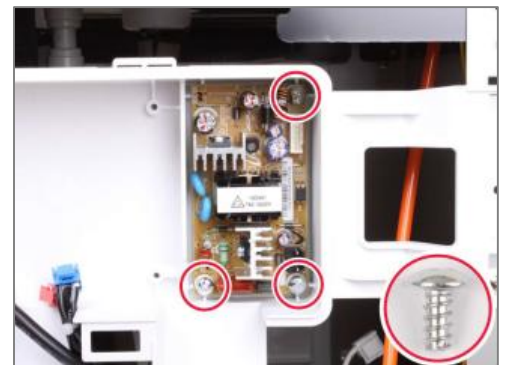

PBA BRACKET

1. Remove the two screws THT 4x10 on the PBA Bracket

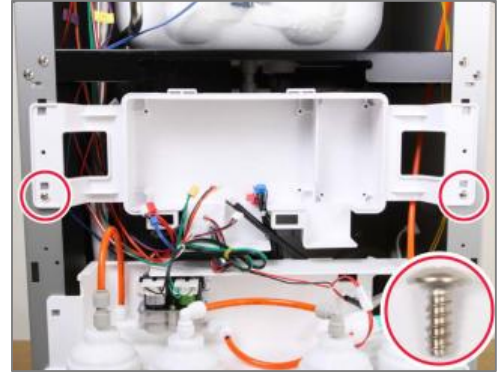

BALLAST

1. Detach the connector from the Ballast

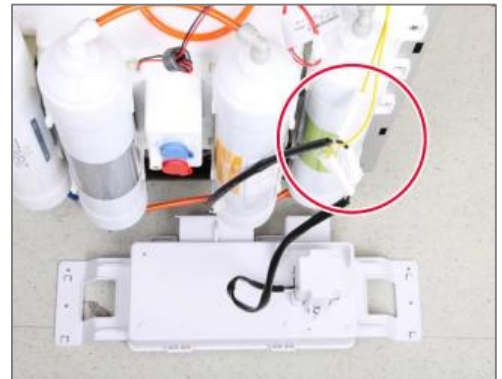

2. Remove the two screws THT 4x8 from Ballast

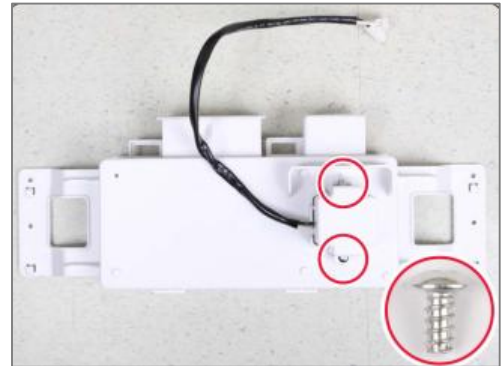

DISASSEMBLING FILTERS

FILTER

1. Remove fittings attached to the filters with a flathead screwdriver.
2. Remove all Filters in direction shown.



VALVE AUTOMATION DRAIN CONTROL

1. Remove Valve-Automation Drain Control connected to the filter with a flathead screwdriver.



DISASSEMBLING FILTER BRACKETS

COLD WATER CONNECTOR DRAIN ASSEMBLY

1. Remove the Cold Water Connector Drain Cap.
2. Rotate the Cold Water Connector Drain Assembly in the direction shown with needle nose pliers.
3. Line up the Cold Water Connector Drain Assembly to the groove on the Filter Bracket. Push it in the direction as shown with needle nose pliers.

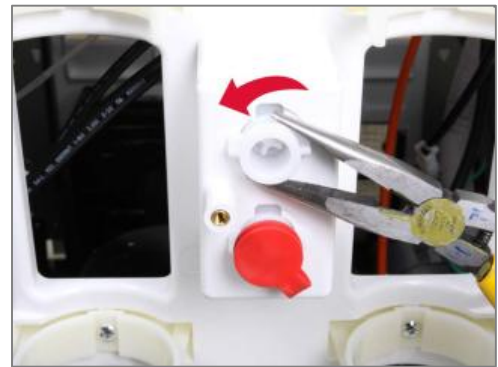

HOT WATER CONNECTOR DRAIN ASSEMBLY

1. Remove the Hot Water Connector Drain Cap.



2. Rotate the Hot Water Connector Drain Assembly in the direction shown with needle nose pliers.



3. Line up the Hot Water Connector Drain Assembly to the groove on the Filter Bracket. Push it in the direction as shown with needle nose pliers.

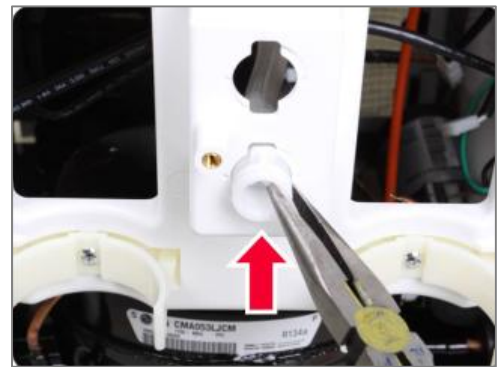

VALVE FEED NOS

1. Remove the connector from Valve Feed Nos



2. Remove the fitting attached to Valve Feed Nos with a flathead screwdriver.



3. Remove the single screw THT 4x8 on Valve Feed Nos.



SENSOR-E LPS ASSEMBLY

1. Remove the fitting attached to Sensor E LPS Assembly with a flat head screwdriver.

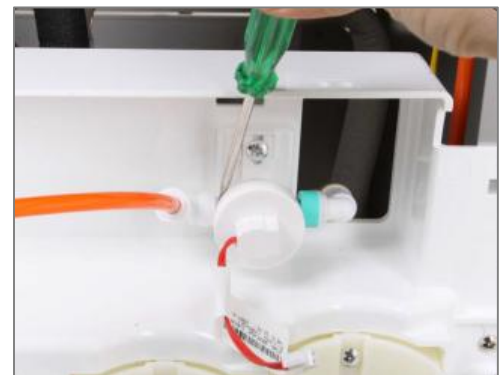

2. Remove the single screw THT 4x8 on the SENSOR-E LPS Assembly.



FILTER BRACKET

1. Remove the four screws THT 4x10 on the Bracket Filter.

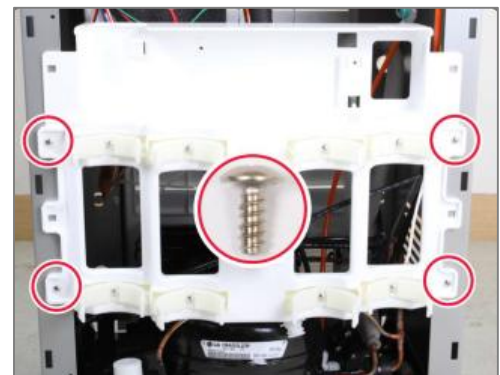

2. Completely remove the Bracket Filter in the direction shown.



CLIP FILTER C2

1. Remove the eight screws THT 4x12 on Clip Filter C2.

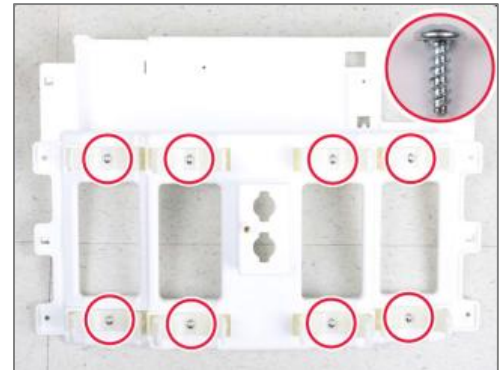

CAPACITOR RUNNING

1. Remove the connector from Capacitor Running.
2. Remove the single screw THT 4x16 on Capacitor Running.

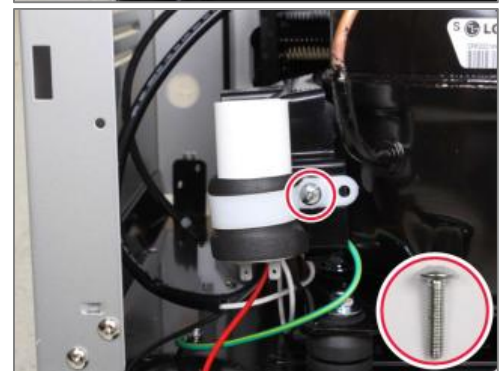
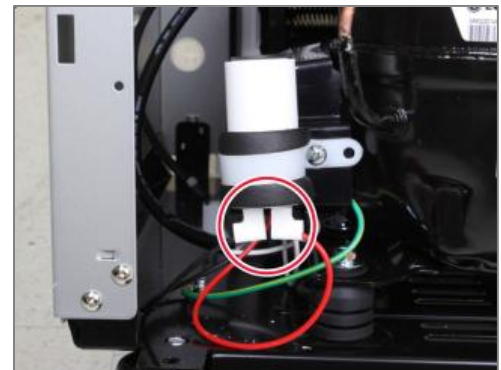

DISASSEMBLING MODULE ASSEMBLY BRACKETS

ULTRAVIOLET STERILIZER MODULE ASSEMBLY

1. Remove the hose connected to the Ultraviolet Sterilizer Module Assembly with a flathead screwdriver.

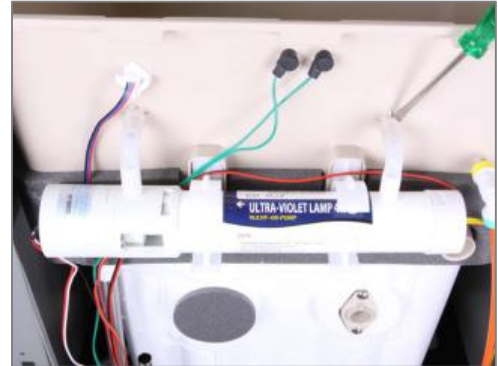

2. Remove the Ultraviolet sterilizer in direction shown.



ULTRAVIOLET STERILIZER CLIP SUS

1. Remove the two screws THT 4x12 on the ULTRAVIOLET STERILIZER CLIP SUS

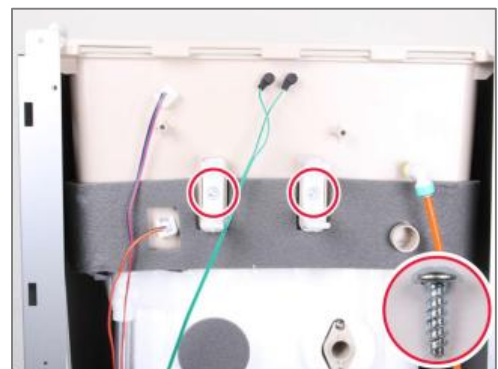

OVERFLOW SENSOR

1. Remove the two Rubber Tubes connected to the Overflow Sensor
2. Remove the two screws on the Sensor Overflow with a Phillips screwdriver.

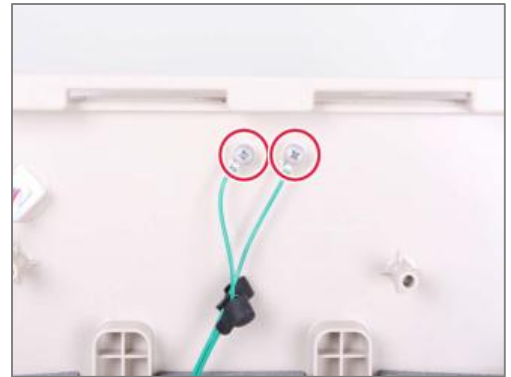

CTS WATER LEVEL N SENSOR

1. Remove the clip on the CTS Water Level N Sensor with a Flathead Screwdriver.
2. Remove the CTS Water Level N in direction shown.



CTS WATER LEVEL P SENSOR

1. Remove the CTS Water Level P Sensor Clip with a Flathead Screwdriver.
2. Remove the CTS Water Level P Sensor in direction as shown.

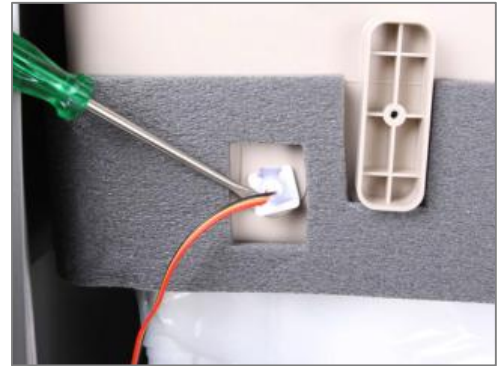

COLD TEMPERATURE SENSOR ASSEMBLY

1. Remove the two screws THT 4x10 on the Cold Temperature Sensor Assembly
2. Remove the Cold Temperature Assembly Sensor in direction as shown.

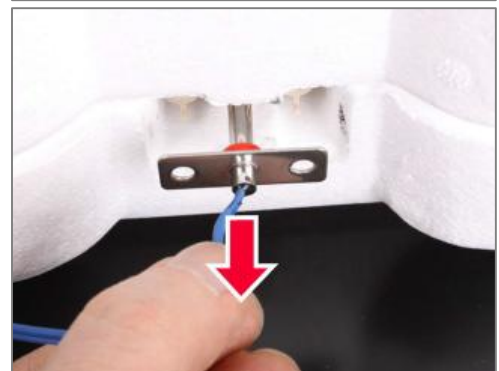
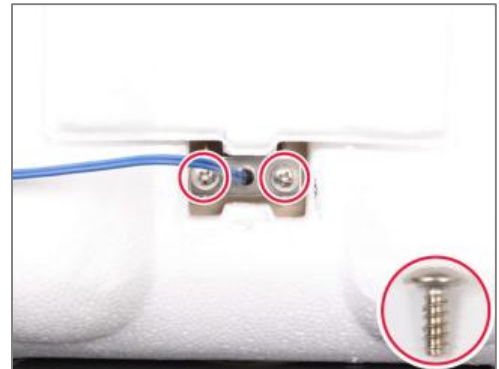

STRAIGHT CONNECTOR DISASSEMBLY

1. Remove the two screws THT 4x10 on the Straight Connector Assembly

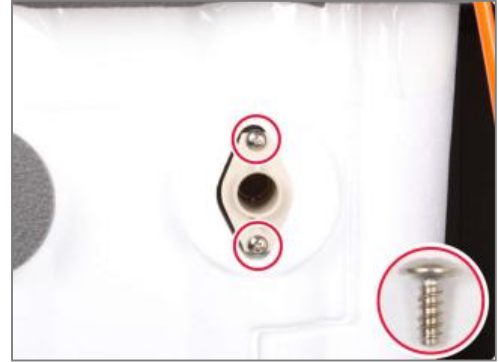

FITTING

1. Remove the fitting attached to the Main Tank Assembly with a flathead screwdriver in direction shown.



REAR COVER DISASSEMBLY

REAR COVER A

1. Remove the four screws THT 4x12 on the Rear A Cover

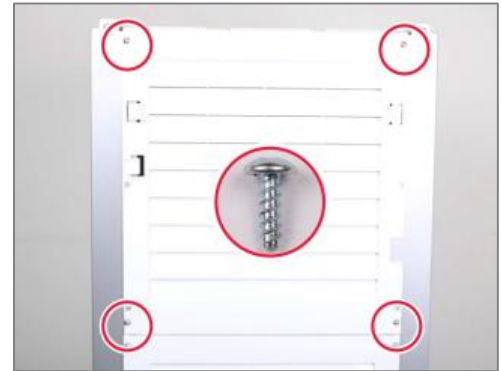

2. Remove Rear A Cover in direction shown

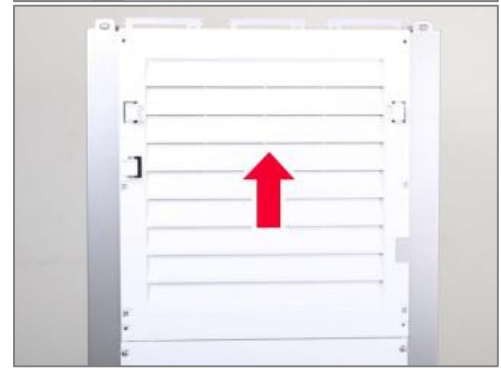

3. Remove the four screws THT 4x12 on the Rear A Cover



4. Remove the Rear A Cover in direction shown



AIR FILTER

1. Remove the two screws THT 4x10 on Air Filter

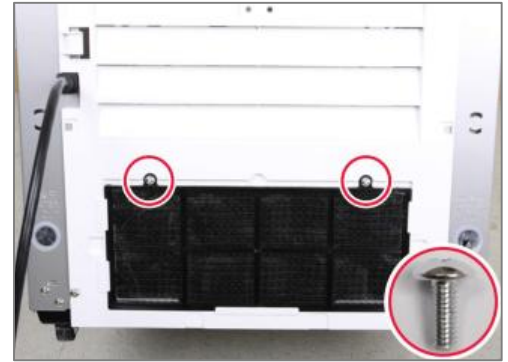

2. Pull the Air Filter towards you and remove in the direction shown.

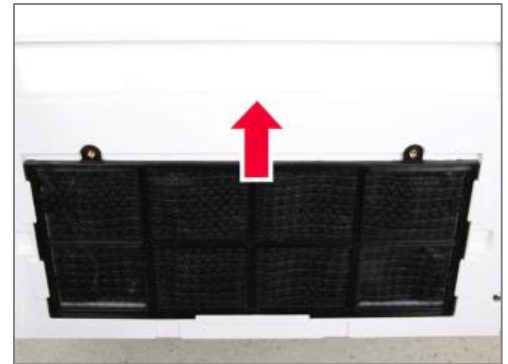

REAR B COVER ASSEMBLY

1. Remove the four screws THT 4x12 on the Rear B Cover Assembly.

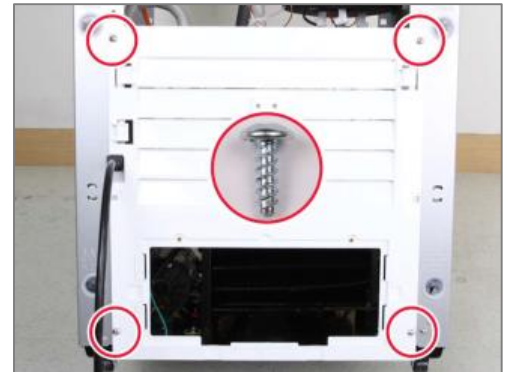

2. Remove the Rear B Cover in the direction shown.

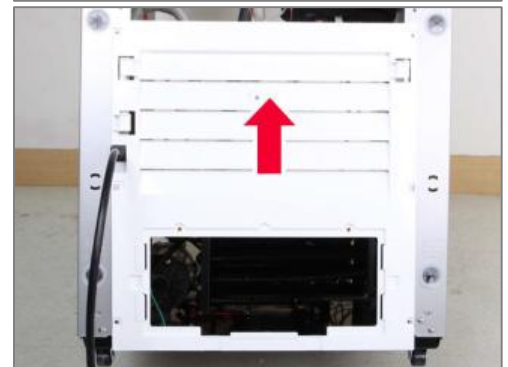

POWER CORD ASSEMBLY

1. Remove the single screw PHT 3x8 (washer) on the Power Cord Assembly.
2. Remove the Power Cord Assembly in direction shown.

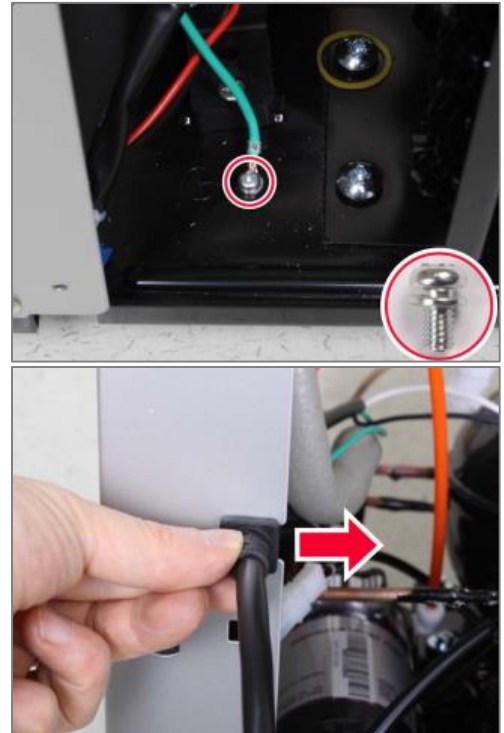

PRE-INSTALLATION INSTRUCTIONS

⚠ DANGER! ELECTRICAL SHOCK HAZARD.

Only qualified personnel who have read and understand this entire manual should attempt to install, or service this unit, failure to do so could result in death or serious injury. DO NOT plug into an electrical supply until specifically instructed.

⚠ WARNING! ALWAYS SANITIZE BEFORE USE.

Sanitize before use to eliminate any potential microbiological contaminates.

Materials Needed:

- Personal Protective Equipment. Rubber or Nitrile Safety Gloves and Protective Eyewear
- Phillips Screwdriver
- Temperature Gage
- Water Pitcher or Container to collect water from the faucet
- 20 Liter (5 gallon) container or drain basin
- Sanitizer - Household Bleach (5.25% Sodium Hypochlorite) or Citric Acid Based Cleaner
- ¼" Plastic Tubing, at least 4 feet in length, and assorted ¼" quick connect fittings
- TDS Meter and Test Strips for measuring chlorine - Optional

1. Unpack the **Waterlogic WL800 Water Treatment System** and check exterior for damage.

⚠ WARNING! WL800 Water Treatment System IS HEAVY.

Use proper lifting aids and handling techniques to avoid injury. Use assistance as single person lift could cause injury. Always drain before handling and transporting and handling to reduce the weight of the unit.

2. Remove the Drip Tray. Remove screw located on the lower front cover. Removing this screw will allow access to the inside serviceable components



3. Press down on the Front Cover Lower Assembly and remove in the direction shown



Flush Filters

CAUTION! FILTER FLUSH REQUIRED.

In order for our filters to perform as represented and to provide the best quality water possible, it is essential that filters be replaced periodically. The frequency of filter changes depends upon your water quality and your water usage. For example, if there is a lot of sediment and/or particles in your water, then you will have to change your filters more frequently than a location with little to no sediment. Be sure to replace your filters whenever you notice a decline in the performance, whether it is a drop in flow rate and/or pressure or an unusual taste in the water.

4. Flush thoroughly per filter manufacturers' recommendation with fresh water to drain.
5. Once flushed, install the filters. Following the flow direction on the filter.

NOTE: Filters should not be flushed prior to 24 hours before installation to limit Microbial Growth.

Sanitizing

Sanitize using a household bleach solution or other approved cleaner throughout the cold and sparkling water circuits. Follow all instructions on the sanitizer and flush with fresh water through the faucet until odor and taste is acceptable.

WARNING! USE PROPER PERSONAL PROTECTIVE EQUIPMENT

Always ensure proper ventilation and use proper personal protective equipment such as gloves and eye protection when using chemicals. Refer to Material Safety Data Sheet for specific requirements of each chemical product. Take all necessary precautions to prevent sanitizer from contacting eyes, clothing, and any other surfaces in could damage (carpets).

6. Connect 40-60 psi regulated, potable water supply to the water inlet bulkhead fitting located on the back of the unit. Turn on water supply and check for leaks.

DANGER! ELECTRICAL SHOCK HAZARD.

Do not plug in unit unless qualified. Only qualified personnel who have read and understand this entire manual should attempt to install or service this unit.

7. Connect **WL800 Water Treatment System** to power and allow unit to fill completely.
8. Mix 2 liters (½ gallon) of sanitizer per directions or use Bleach Solution (1 teaspoon = 1/6 oz. = 5 ml = ½ cap full) of household bleach (Sodium Hypochlorite 5 - 10% Concentration) with 1/2 gallon of water. Always ensure sanitizer is compatible with stainless steel and acetal plastic.

9. Pour sanitizer into reservoir.

⚠ WARNING! *Use Personal Protective Equipment. Gloves and Eye Protection Required. The first 2 or 3 gallons of water will contain concentrated sanitizer. Use extreme care!*

⚠ CAUTION! *USE SANITIZER COMPATIBLE WITH STAINLESS STEEL AND ACETAL PLASTIC. Do not allow the sanitizer solution to remain in the system for more than 10-15 minutes unless otherwise directed by the sanitizer manufacturer.*

Flushing the Sanitizer from the Machine

10. Place a pitcher, catch basin, or other container under the faucet of the **WL800 Water Treatment System**.

11. Flush the Cold Tank. Run several gallons of water through the faucet by dispensing cold water to dilute and remove the sanitizer from the cold circuit. You can use chlorine test strips to evaluate the water.

Fill the Hot Tank

12. Press the Hot Cup Touch Lever to fill the hot tank. Water will dispense from the faucet once the hot tank is full. Flush until water is clear.

⚠ WARNING! **HOT CIRCUIT IS NOT SANITIZED. WATER MUST EXCEED 171° F**
Water in the hot circuit is not sanitary until the temperature over 171°F for 5 minutes. Do Not Ingest and avoid contact until heater is turned on for at least 5 minutes.

Compressor Test

13. Heater and compressor will turn on automatically once water level has reached the full level sensor.

14. Allow unit to run for 1 hour. Check hot and cold temperatures. Cold = 41°, Hot = 187°.

15. Once the machine reaches its target temperature, the compressor and fan will shut off. Draw a glass of cold water and verify it has been chilled to proper temperature.

⚠ WARNING! **VERY HOT WATER CAN BURN OR SCALD.**
Hot water should be dispensed carefully into insulated container to avoid injury.

Drain the WL800 for Transport

16. Drain the **WL800** for transportation per the Draining Instructions in this manual.

⚠ WARNING! **STORE UNIT EMPTY. ALWAYS SANITIZE BEFORE REUSE.**
The unit must be completely drained and sealed before storing to avoid stagnation and reduce microbiological contamination (potential bacterial growth).

WL800 DRAINING INSTRUCTIONS

⚠ WARNING! *WATERLOGIC WL800 WATER TREATMENT SYSTEM IS A HEAVY OBJECT.*

1. Turn off water supply and disconnect from unit.
2. Unplug power supply
3. Remove drip tray and lower front panel.

Remove Grill in direction shown



Detach the Grill Tray Assembly as shown



Remove the screw (THT 4X10) located on the Lower Front Cover Assembly as shown.



Press down on the Lower Front Cover Assembly and remove in the direction shown



4. Connect Drain Tube.
5. Replace Lower Front Panel and Drip Tray.

INSTALLATION PROCEDURES

Safety and Installation Guidelines

Ensure all Local, State, and Federal Laws and Codes including health and safety guidelines are met when installing **Waterlogic** Equipment. Only qualified service technicians should attempt installation and service of **Waterlogic** Equipment.

- ⚠ WARNING! ELECTRICAL SHOCK HAZARD.** *Always unplug (isolate from power supply) to prevent electrical shock except where electrical tests are specified.*
- ⚠ WARNING! IMPROPER SUPPLY OR CONNECTION CAN RESULT IS RISK OF SHOCK.** *Connect to a 15 amp 120V 60Hz properly grounded outlet (GFI is recommended). Ensure polarity is correct and always use a 3-prong outlet. Consult a qualified electrician if you have any questions.*
- ⚠ WARNING! USE ONLY WATERLOGIC SUPPLIED POWER CORD (EL-5001-A).** *Locate system within 5 feet of power supply. Never use an extension cord or adapter. Do not use a damaged power cord or plug. Keep power cord out of heavy traffic areas and away from heat sources. Do not, under any circumstances, remove ground prong or alter the power cord. Never pull the power plug from the outlet with a wet hand or allow the plug to get wet. Failure to use the supplied power cord will void UL Certification and Warranty.*
- ⚠ CAUTION! INDOOR USE ONLY.** *Never exposed to direct sunlight, heat sources, or ambient air temperature above 36°C (97°F) or below 10°C (50°F). Install indoors and keep unit away from excessive humidity. Never expose to freezing temperatures. Ensure there is adequate clearance around the unit to allow refrigeration system condenser to dissipate heat. Warmer environments require more clearance around the unit. Minimum clearance around all surfaces of the machine is 2-inches. Installs where the ambient temperature exceeds 27°C (80°F), require a minimum of 4-inches clearance for proper heat dissipation and efficient operation.*
- ⚠ CAUTION! USE A WATER PRESSURE REGULATOR.** *Waterlogic will not be responsible for injury or damage caused by excessive water pressure. Operating pressure must be 40 psi to 60 psi. Be aware any of potential pressure surges caused by building/municipal pumping stations.*
- ⚠ CAUTION! USE UV STABILIZED SUPPLY LINES.** *Feed the unit with a potable ambient or cold water supply only. Feed water over 41°C (105°F) can damage the treatment components. Water block devices and external leak detectors are strongly recommended. Locate the unit as close to the water supply and the electrical connections as possible.*
- ⚠ WARNING! STORE UNIT EMPTY. ALWAYS SANITIZE BEFORE USE.** *The unit must be completely drained and sealed before storing to avoid stagnation and reduce microbiological contamination (potential bacterial growth). Sanitize before use to eliminate any potential microbiological contaminates*

The WL800 Water Treatment System can be combined with RO Filtration Systems. RO will require a drain connection. Refer to all applicable plumbing codes and standards in your area for these requirements (air gap connections and back flow prevention may be necessary).

Pre-installation and sanitization procedures as prescribed in this manual must be performed before installing the **WL800 Water Treatment System**.

Always install indoors and place the **Waterlogic WL800 Water Treatment System** on a firm, flat and stable surface.

Attach the water supply line to the orange 1/4" feed water tube at the inlet bulkhead fitting on back of the unit. **Waterlogic** requires the use of a water pressure regulator. Water feed pressure must be between 40-60 psi. Turn on the water supply and check for leaks.

1. Connect the power cord to the back of the **Waterlogic WL800 Water Treatment System** and to a 120 Volt supply.

2. Allow unit to fill.

3. Dispense Cold Water

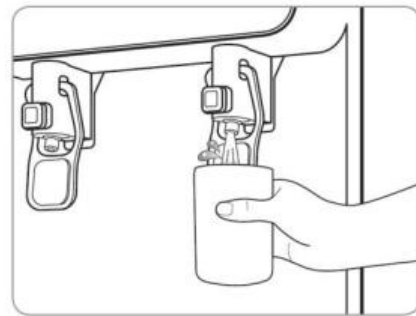

4. Dispense Hot Water

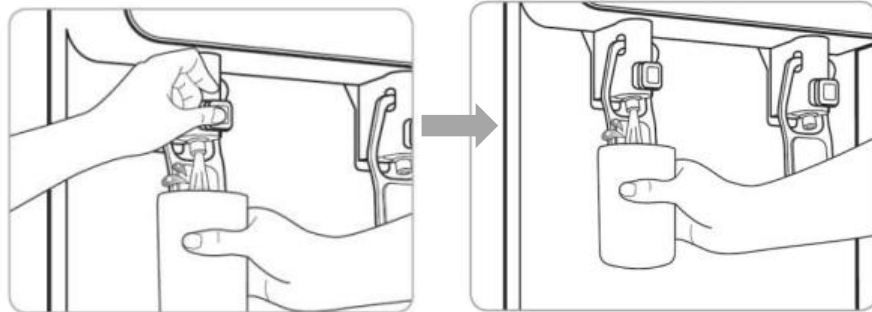

5. Move the **Waterlogic WL800 Water Treatment System** into its final operating position. Be sure that a minimum of 2" clearance is maintained around both the sides and the back of the unit. This is important to allow proper airflow and heat exchange of refrigeration system.

6. Level unit using the adjustable feet to level if necessary. Never install on incline.

7. Once the unit is at the target temperature(s), sample the water to ensure water meets expectations and additional rinsing or adjustment is not required.

8. Check the unit for any leaks. External Leak Protection is always recommended.

SERVICE REQUIREMENTS

⚠ WARNING! *Read and understand the contents of this manual before attempting to service WL800 Water Treatment System. Failure to follow the instructions in this manual could result in death, serious personal injury, or severe property damage. Only trained and qualified technicians should attempt to install, maintain, or service Waterlogic Equipment.*

1. Visually inspect all electrical and water connections for signs of wear or damage.

⚠ DANGER! ***HIGH VOLTAGE ELECTRICAL HAZARD.** Unplug before inspection and service.*

2. **Waterlogic** recommends changing the UV Lamp every 12 months.

⚠ WARNING! ***ULTRAVIOLET RADIATION.** Protect your skin and eyes against ultraviolet rays. Never look directly at an operating UV light. Disconnect before removing UV Lamp.*

⚠ CAUTION! ***UV LAMPS ARE HAZARDOUS.** Lamps are considered Hazardous Waste and must be disposed of accordingly. Refer to Product MSDS sheet for details.*

3. The filters should be replaced every 12 months, or 7570 liters (2000 gallons), whichever comes first. Local water conditions will dictate your exact filter requirements and service intervals. Flush 20 liters (5 gallons) of water through the filters to rinse carbon fines. Do not rinse the filters through the unit solenoid valve(s) and tanks if at all possible to avoid contamination.
4. Clean and sanitize external surfaces of the unit. Use soap and water or chemicals that are compatible with ABS plastic and will not damage or degrade the product surfaces.
5. Remove and clean the Faucet. Replace as needed.

⚠ WARNING! ***SANITIZER MAY CONTAIN HAZARDOUS CHEMICALS.** Use of proper personal protective equipment such as rubber gloves and eye protection is required.*

REPLACEMENT COMPONENTS

Component	Part No.	Frequency of Replacement
UV Light and Pump Assembly	3123954 (WLCP P/N 16-5140)	Every 12 months, or as required.
Hot Tank (plus controls)	3123938 (WLCP P/N 16-5020)	Every 3-5 Years depending on usage. Descaling Hot Tank may be required on a regular basis depending upon filtration and local water conditions. See Service Section in this manual for instructions on how to descale the Hot Tank.

Replacement parts can be obtained from *Waterlogic* or an *Authorized Waterlogic Dealer*. See Parts Layouts, Drawings, and Lists for additional repair parts.

NOTE:

At the **end of this product's life**, ensure that it is disposed of in an environmentally friendly manner which is fully compliant **with all Federal/State/Local Requirements and Guidelines**.

DESCALING THE HOT TANK

1. The Hot Tank requires removal of mineral deposits (descaling) on a regular basis, depending upon filtration and local water conditions. Descaling is an important process that removes calcium deposits, or scale, that can build up inside a tank over time. Calcium and scale is non-toxic but left unattended, it will hinder your unit's performance.

Descaling should take place every 6 to 12 months to preserve the long-term health of your unit. Use non-toxic cleaner such as ScaleKleen, DEZCAL, 20% Citric Acid Solution, or Undiluted Vinegar Solution to remove mineral deposits as directed by the manufacturer.

⚠ WARNING! PERSONAL PROTECTIVE EQUIPMENT REQUIRED. Always ensure proper ventilation and use rubber or nitrile gloves and eye protection when using chemicals. Refer to Material Safety Data Sheet for specific requirements of each product.

⚠ CAUTION! STAINLESS STEEL TANK DESCALING.

The Hot Tank is made from stainless steel. Ensure descaling solution is compatible with stainless and always flush the unit completely. Dispose in an environmentally safe manner.

See Hot Tank Descaling Video and training procedure located on the **Partner Area of the Waterlogic Website** for more detailed instructions. www.waterlogic.us

Materials Needed:

- Personal Protective Equipment. Rubber or Nitrile Safety Gloves and Protective Eyewear
 - Phillips Screwdriver
 - Temperature Gauge
 - Water Pitcher or Container to collect water from the faucet
 - 20 Liters (5 gallons) container or drain basin
 - Citric Acid Based Cleaner
 - Food Coloring
2. Mix descaler per directions and 3 drops of food coloring into the descaling cartridge.
 3. Turn off Power to unit.
 4. Turn off Water Supply.
 5. Remove Top Cover.



6. Remove Drip Tray and Lower Front Panel.
7. Drain Unit using Supplied Blue Drain Tube.
8. Open Reservoir Cover.
9. Pour Descale solution into Hot Tank using a funnel.



10. Turn on Water and Power Supplies.
11. Allow unit to refill.
12. Allow Descale Solution to Remain in Hot Tank for 15 minutes (length of time may vary depending on water conditions).
13. Flush Hot Tank through Faucet.
14. Replace Lower Front Panel and Drip Tray.
15. Replace Reservoir Cover
16. Replace Top Cover

⚠ WARNING! HOT WATER HAZARD. *Unit Produces Very Hot Water and Steam. Always use insulated and chemically compatible containers and let unit cool down before draining the hot tank to avoid injury.*

⚠ CAUTION! REPLACE HOT TANK (WLCP P/N HT-3021) EVERY 3-5 YEARS DEPENDING ON USAGE. *The Hot tank and its controls should be replaced a minimum of every three to five years depending on usage to ensure efficient operation.*

17. Always ensure unit is performing to the customer's satisfaction.

⚠ CAUTION! RIBBON CONNECTORS MUST BE FULLY ENGAGED. *Ensure ribbon connectors are properly engaged and fully seated in front PCB (Printed Circuit Board) to avoid intermittent/connectivity issues any time the front hatch panel is accessed.*

⚠ WARNING! REINSTALL ALL PANELS AND COVERS. *Always reinstall all panels, protective covers, and fasteners after servicing equipment. Failure to do so could result in severe personal injury and will void the certifications and warranty of the equipment.*

WL800 EXPLODED VIEW AND PARTS LIST

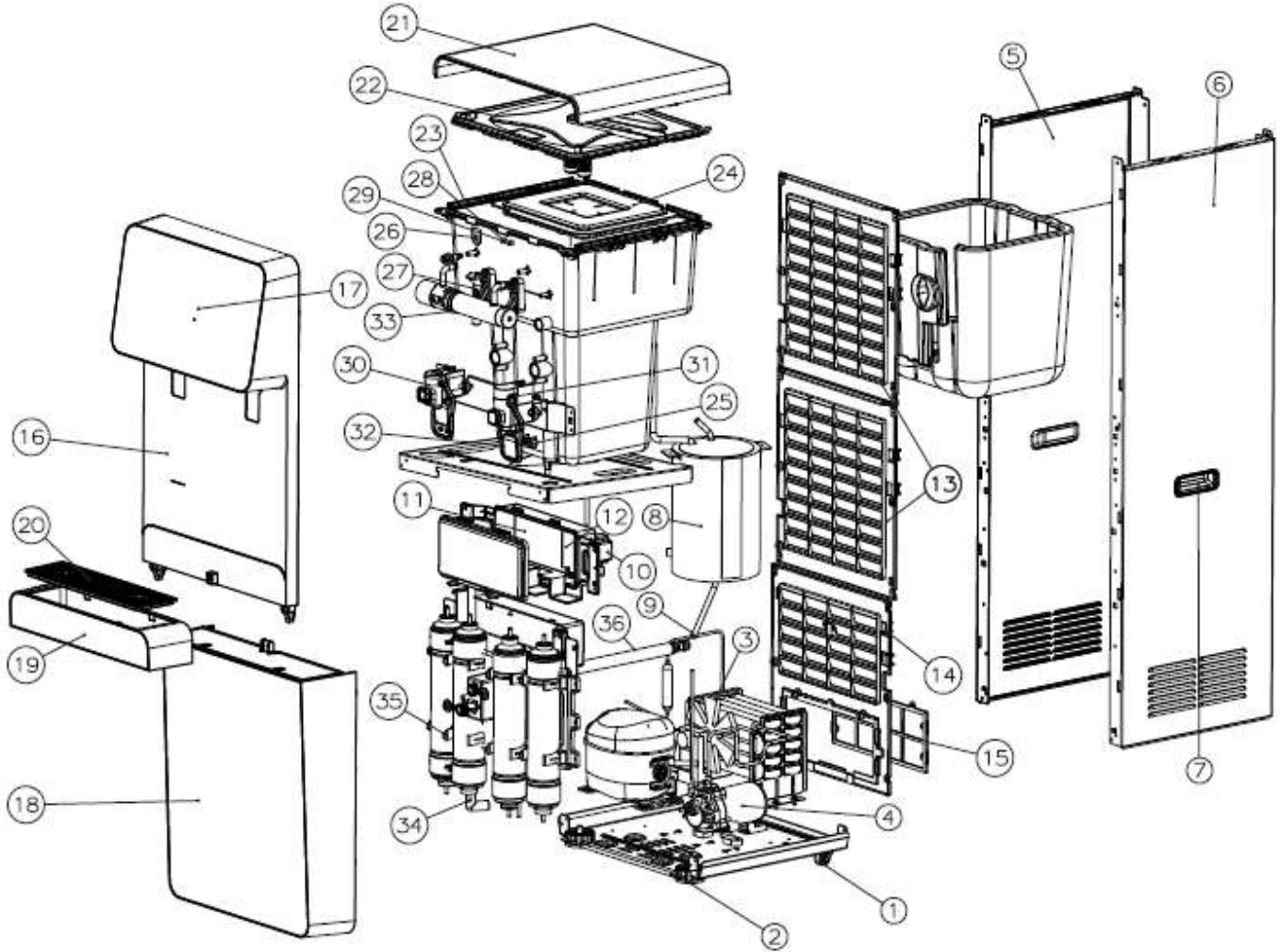

WL800 PARTS LIST





No.	P/N	Description	WLCP P/N	Stocked?	Image
1	3103311	Caster-B	16-5000 Same as 16-1202	Yes	
2	3306158	Black Caster - E	16-5005	Yes	
3	3123934	Fan – Unit Assembly	Fan Assembly N/A	16-1208 Yes	
4	3122366	Booster Pump	16-5200	Yes	
5	3123936	Left Side Cover Assembly – with Handle	16-5010	Yes	
6	3123937	Right Side Cover Assembly – with Handle	16-5015	Yes	
7	3101463	Handle	16-1096	Yes	
8	3123938	Heating Tank Assembly	16-5020	Yes	
9	3306113	Hot Water Drain Assembly Connector	16-5025	Yes	
10	3306116	Ballast	16-5030	Yes	
11	3123939	PBA-Main Assembly	16-5035	Yes	

12	3123940	PBA-SMPS	16-5040	Yes	
13	3110507	Rear Cover – A	16-5045	Yes	
14	3110508	Rear Cover Assembly – B	16-5050	Yes	
15	3210636	Air Filter	16-5055	Yes	
16	3123945	Upper Front Cover – Needs Silver Insert	16-5060	Yes	
17	3123947	PBA-Front Cover Assembly	16-5065	Yes	
18	3123948	Front Bottom Cover – Needs Silver Insert	16-5070	Yes	
19	3123949	Tray Assembly	16-5075	Yes	
20	3224223	Grill	16-5080	Yes	
21	3123950	Top Cover Assembly	16-5085	Yes	

22	3123944	CAP – Main Tank Assembly	16-5090	Yes	
23	3112502	Clip – Main Tank Sealing	16-5095	Yes	
24	3306123	Separator Board	16-5100	Yes	
25	3110565	Cold Sensor - Temperature Assembly	16-5105	Yes	
26	3306120	Sensor – CTS Water Level N – Upper - White	16-5110	Yes	
27	3306121	Sensor – CTS Water Level P – Lower – Blue	16-5115	Yes	
28	3306122	Overflow Sensor	N/A	No	
29	3110569	Overflow Sensor Assembly Harness	16-5120	Yes	
30	3306114	Hot Water Faucet Safety Assembly	16-5125	Yes	
31	3123952	Cold Water Faucet Assembly	16-5130	Yes	

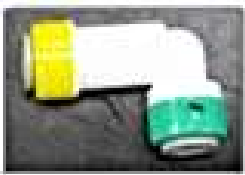
32	3306115	Faucet Lever – Rubber	16-5135	Yes	
33	3123954	Ultra Violet Sterilizer Module Assembly	16-5140	Yes	
34	3306125	Automation Drain Control Valve	16-1100	Yes	
35	3306127	Filter C2 Clip	16-5145	Yes	
36	3103373	Cold Water Drain Assembly Connector	16-5150	Yes	
Not shown	3105086	Valve –Feed NOS	16-5155	Yes	
Not shown	3302612	LPS Sensor –E Assembly	16-1112	Yes	
Not shown	3123935	Leakage Sensor	16-5160	Yes	
Not shown	3306111	Hot Tank Overload / High Limit – Bimetal	16-5165		

Not shown	3306112	Hot Water Temperature Sensor	16-5170	Yes	
Not shown	3224211	Power Cord Assembly	16-5175	Yes	
Not shown	3306117	Snap Ring – E Ring	N/A	No	
Not shown	3100029	Spring	N/A	No	
Not shown	3306118	Support	N/A	No	
Not shown	3103235	Ultra-Violet Sterilizer SUS - Clip	N/A	No	
Not shown	3123955	UV Filter Hose	N/A	No	
Not shown	3306124	Tap Hose	N/A	No	
Not shown	3300750	Elbow Fitting - White	16-5180	Yes	

Not shown	3114063	Elbow Check Valve	16-5185	Yes	
Not shown	3105091	Elbow Fitting – Gray	16-5190	Yes	
Not shown	3302908	Straight Fitting – Gray	N/A	No	
Not shown	3306126 or 3303341 Interchangeable	Faucet Cap	16-5195 or 16-1160 interchangeable	Yes	

WL800 ELECTRICAL DIAGRAM

⚠ DANGER! HIGH VOLTAGE ELECTRICAL HAZARD. PCB (Printed Circuit Board) contains High Voltage. Only trained and qualified technicians should attempt live testing.

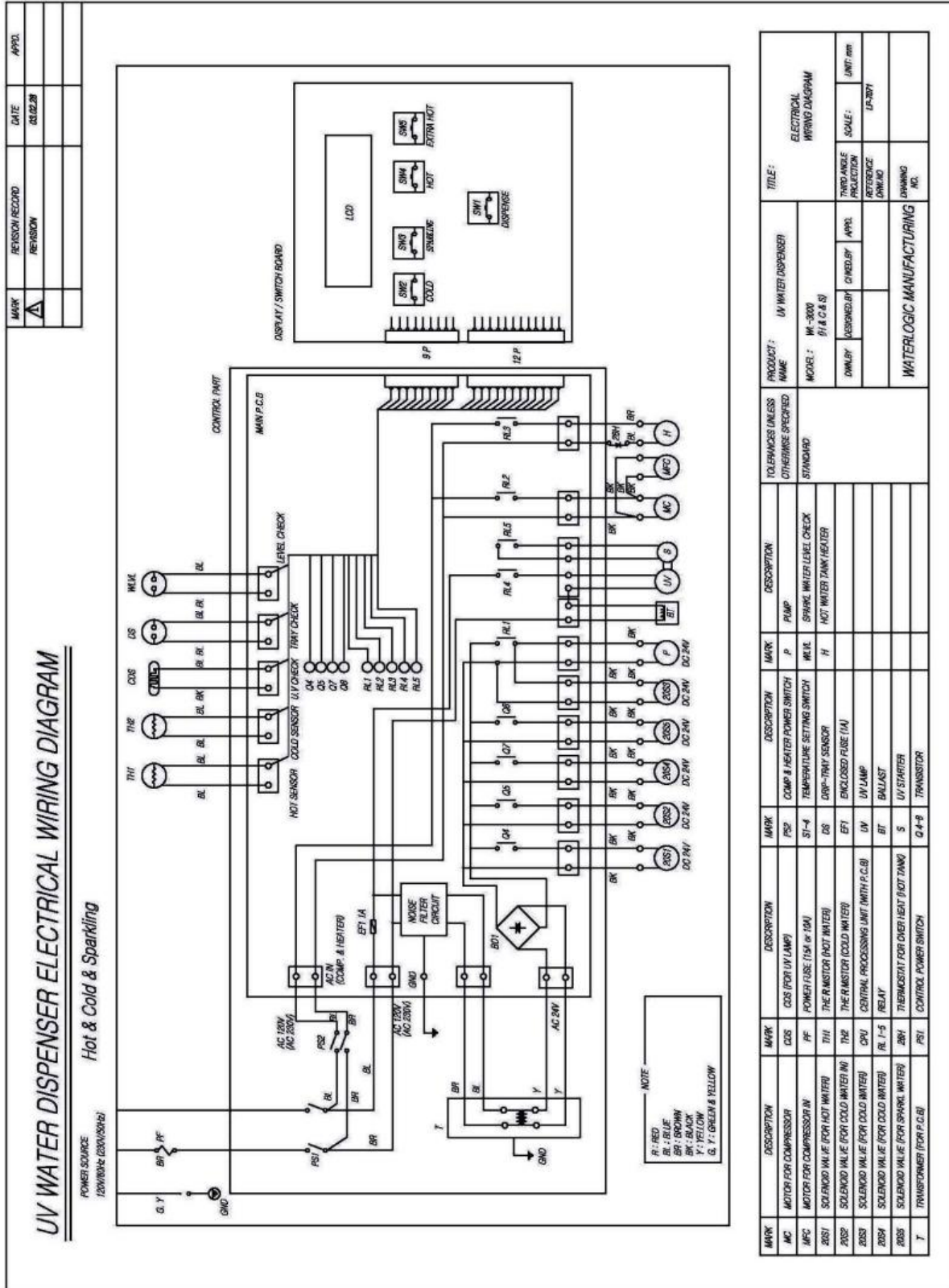

MARK	REVISION RECORD	DATE	APPRO.
A	REVISION	03/02/08	

PRODUCT NAME		TITLE	
UV WATER DISPENSER		ELECTRICAL WIRING DIAGRAM	
MODEL: WK-3000 (F1 & C & S)		SCALE: UNIT: mm	
DESIGNED BY	CHECKED BY	THIRD ANGLE PROJECTION	REFERENCE DRAWING
DESIGNED BY	CHECKED BY	REF: mm	REF: mm
WATERLOGIC MANUFACTURING		DRAWING NO.	

CABLE SPECIFICATIONS

■ Harness – Front PBA

HOUSING : SMH250-06(RED/YEONHO)
 TERMINAL : YST025(YEONHO)

HOUSING : SMH250-06(RED/YEONHO)
 TERMINAL : YST025(YEONHO)

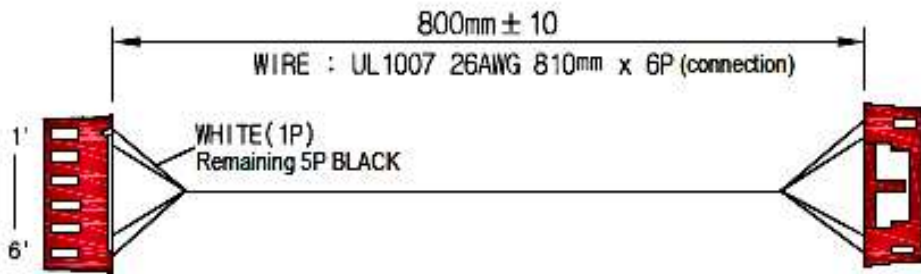

■ Harness – Overflow Sensor

HOUSING : SMH250-03P(YEONHO/YELLOW)
 TERMINAL : YST025(YEONHO)

HOUSING : ST710087-3(KET)
 CAP : SANTOPRENE(ILSHIN)

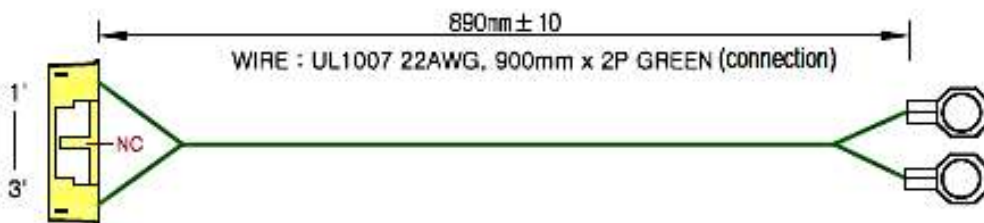

■ Harness – Leak Detector Sensor

HOUSING : L.D.C HOUSING(JAEWON)
 TERMINAL : 61116-1(AMP)

HOUSING : SMH250-02(BLACK/YEONHO)
 TERMINAL : YST025(YEONHO)



* Secure the insulation tube as close to the left housing as possible.

■ Harness – SMPS A

HOUSING : SMH250-06P(YEONHO)
 TERMINAL : YST025(YEONHO)

HOUSING : SMH250-06P(YEONHO)
 TERMINAL : YST025(YEONHO)

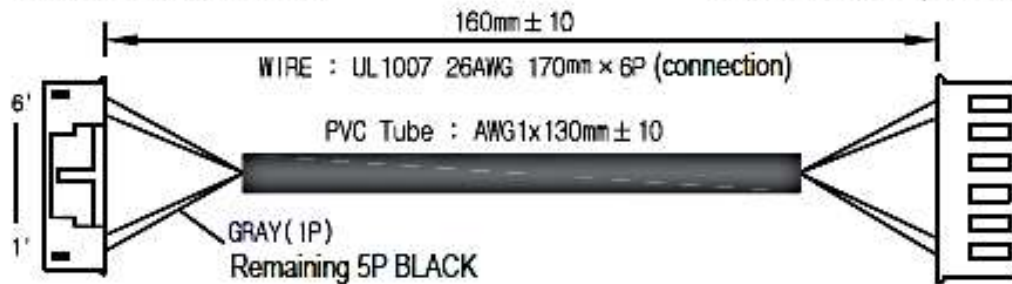

■ Harness – SMPS B

HOUSING : YH396-03V(YEONHO/BLACK)
 TERMINAL : YT396J(YEONHO)

HOUSING : YH396-03V(YEONHO/BLACK)
 TERMINAL : YT396J(YEONHO)

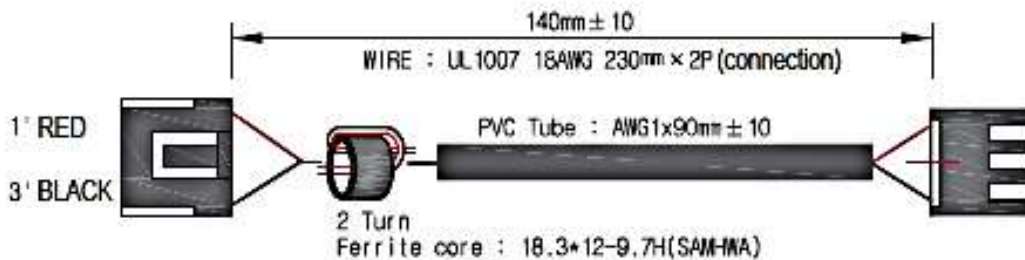

■ Harness – Valve

HOUSING : SMH420-04(YEONHO)
 TERMINAL : SMT420(YEONHO)

HOUSING : MG632202R(KET)
 TERMINAL : ST730863-3(KET)

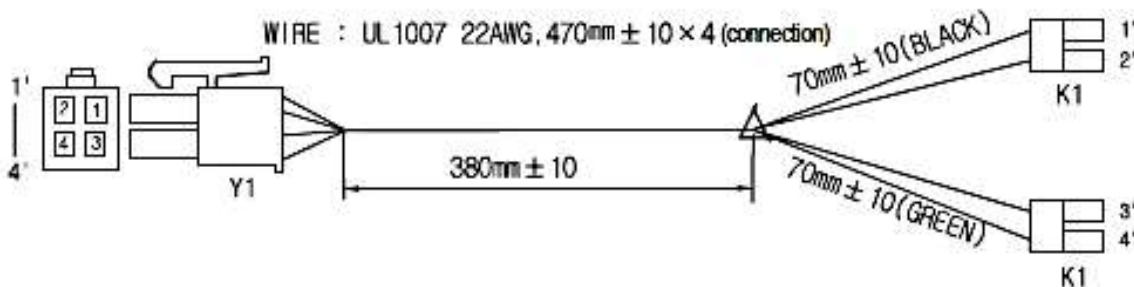

■ Harness – Comp Fan

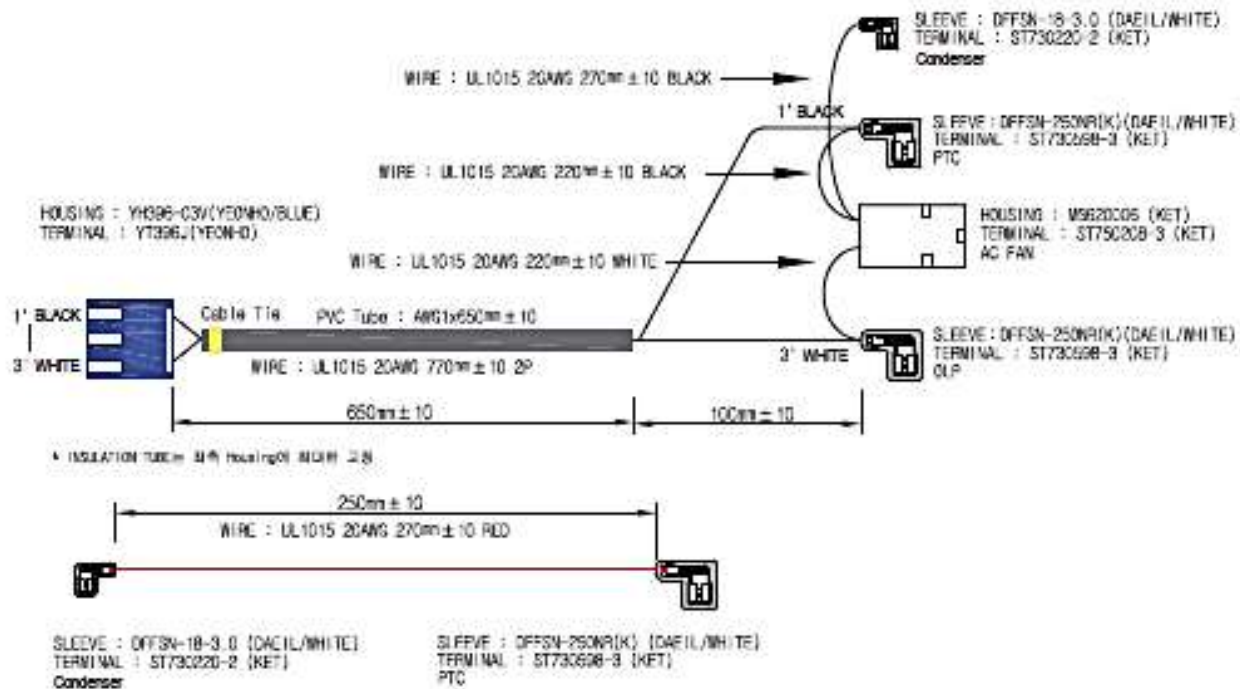

■ Harness – Heater

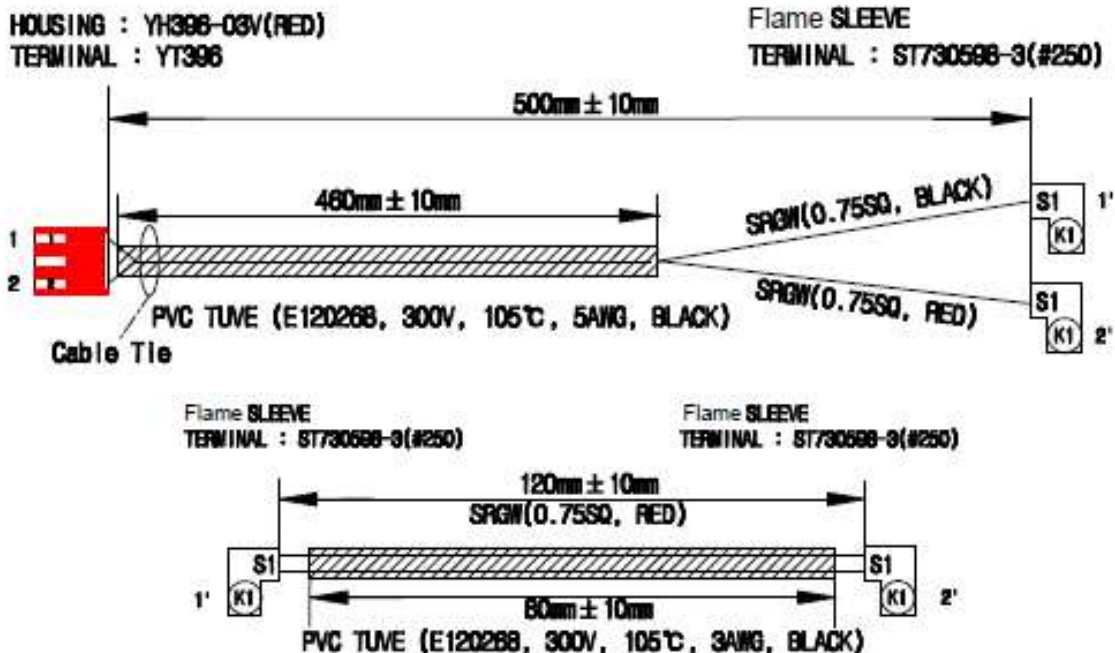

WL800 CIRCUIT DIAGRAMS

MAIN PBA

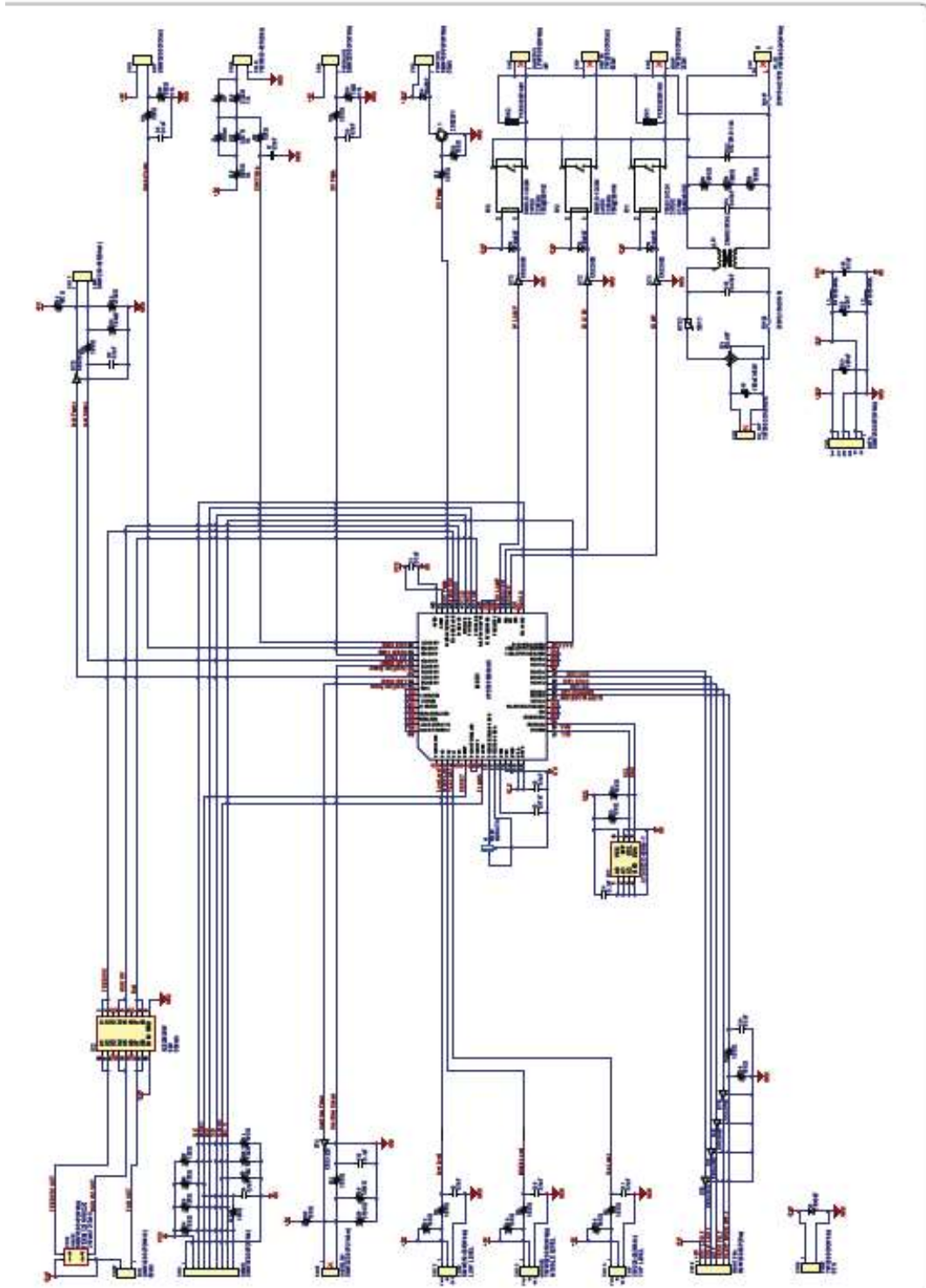

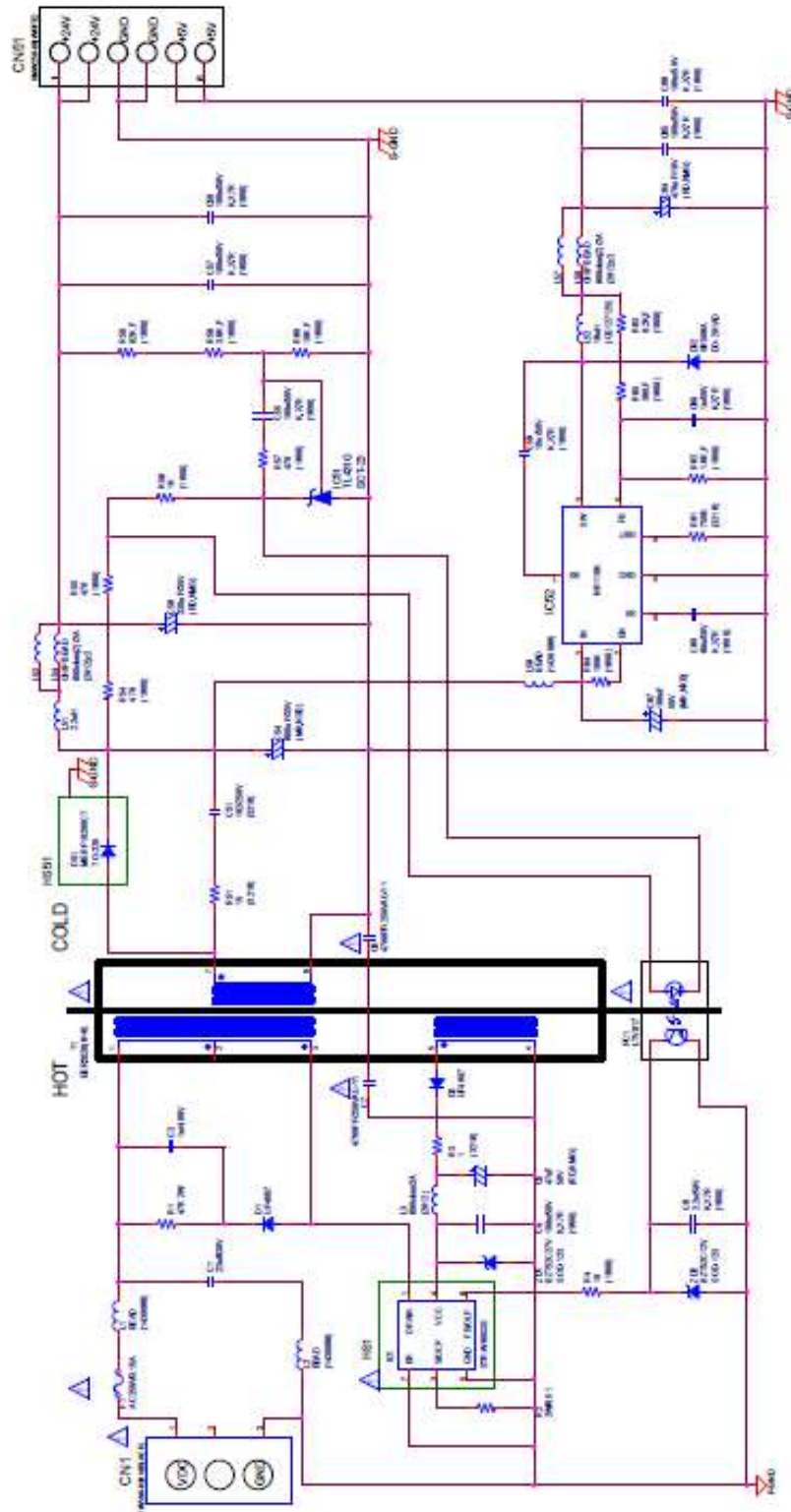

FRONT PBA

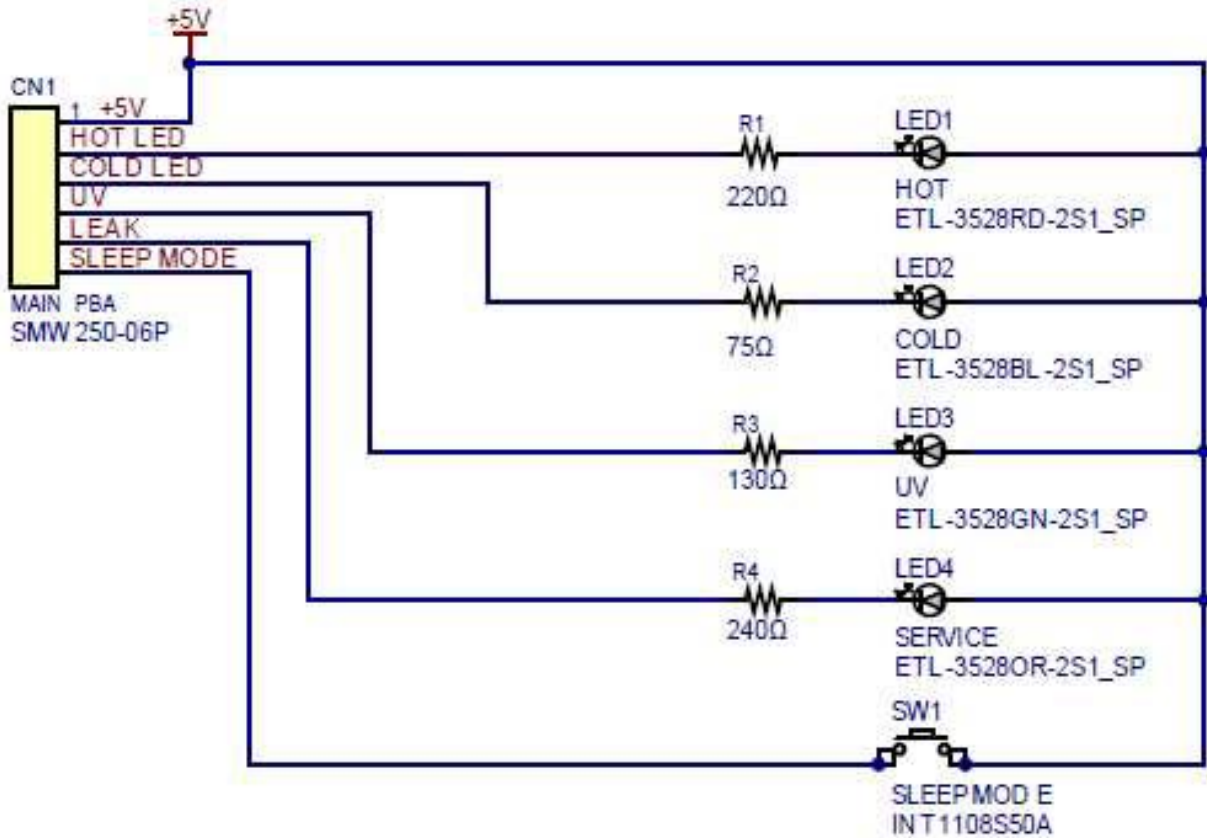

PBA LOCATION DIAGRAM

MAIN PBA

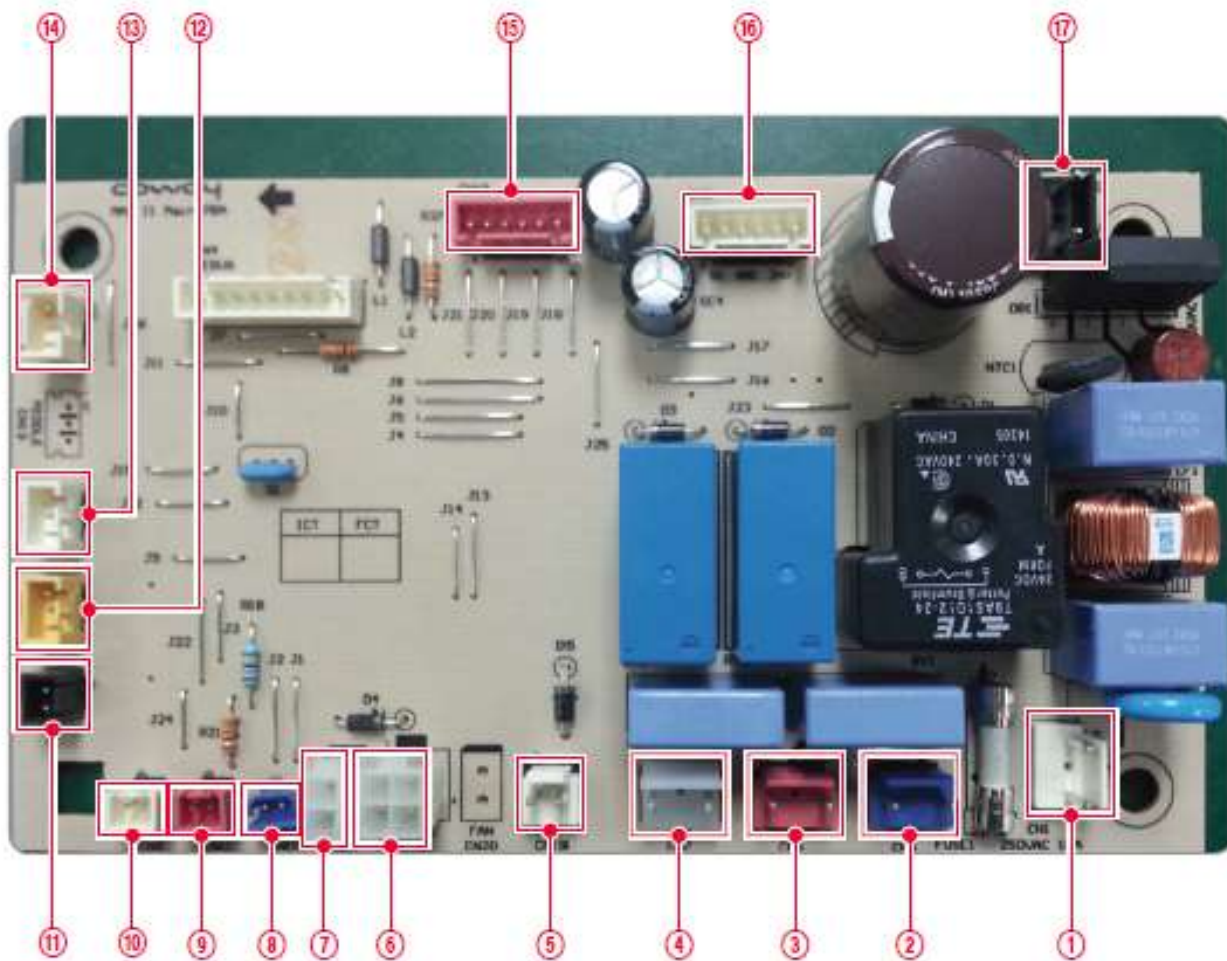

① CN1
AC IN

Pin No.	Signal
1	120 VAC (N)
2	120 VAC (L)

② CN5
COMP

Pin No.	Signal
1	120 VAC (N)
2	120 VAC (L)

③ CN6
HEATER

Pin No.	Signal
1	120 VAC (N)
2	120 VAC (L)

④ CN7
LAMP (UV)

Pin No.	Signal
1	120 VAC (N)
2	120 VAC (L)

⑤ CN9
PUMP

Pin No.	Signal
1	24 V
2	GND

⑥ CN16
VALVE

Pin No.	Signal
1	24 V
2	FEED V/V OUT
3	24 V
4	NOS V/V OUT

⑦ CN8
PUMP (UV)

Pin No.	Signal
1	SIGNAL
2	24 V

⑧ CN10
COLD SENSOR

Pin No.	Signal
1	GND
2	COLD SENSOR

⑨ CN11
HOT SENSOR

Pin No.	Signal
1	5 V
2	HOT SENSOR

⑩ CN9
PHOTO (UV)

Pin No.	Signal
1	PHOTO SENSOR
2	5 V

⑪ CN17
LEAK DETECTOR

Pin No.	Signal
1	LEAK DETECTOR POWER
2	LEAK DETECTOR SENSOR

⑫ CN15
OVERFLOW SENSOR

Pin No.	Signal
1	OVERFLOW POWER
2	OVERFLOW SENSOR

⑬ CN12
LOW LEVEL SENSOR

Pin No.	Signal
1	SIGNAL
2	5 V
3	GND

⑭ CN14
TOP LEVEL SENSOR

Pin No.	Signal
1	SIGNAL
2	5 V
3	GND

⑮ CN18
MAIN - FRONT PBA

Pin No.	Signal
1	5 V
2	HOT LED
3	CHILLING LED
4	UV LED
5	SERVICE LED
6	SLEEP MODE SW

Ⓢ CN3
SMPS - MAIN

Pin No.	Signal
1	24 V
2	24 V
3	GND
4	GND
5	5 V
6	5 V

Ⓢ CN2
SMPS - MAIN (POWER)

Pin No.	Signal
1	GND
2	VDD

SMPS

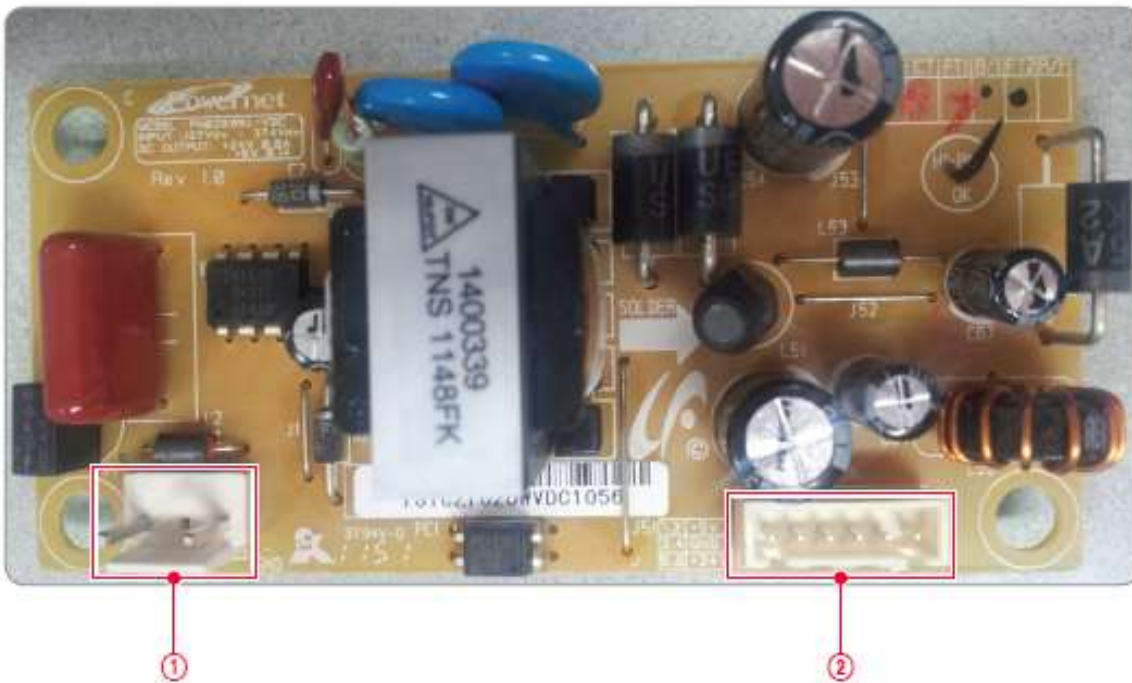

① CN1
SMPS - MAIN (POWER)

Pin No.	Signal
1	VDD
2	GND

② CN51
SMPS - MAIN

Pin No.	Signal
1	24 V
2	24 V
3	GND
4	GND
5	5 V
6	5 V

SMPS

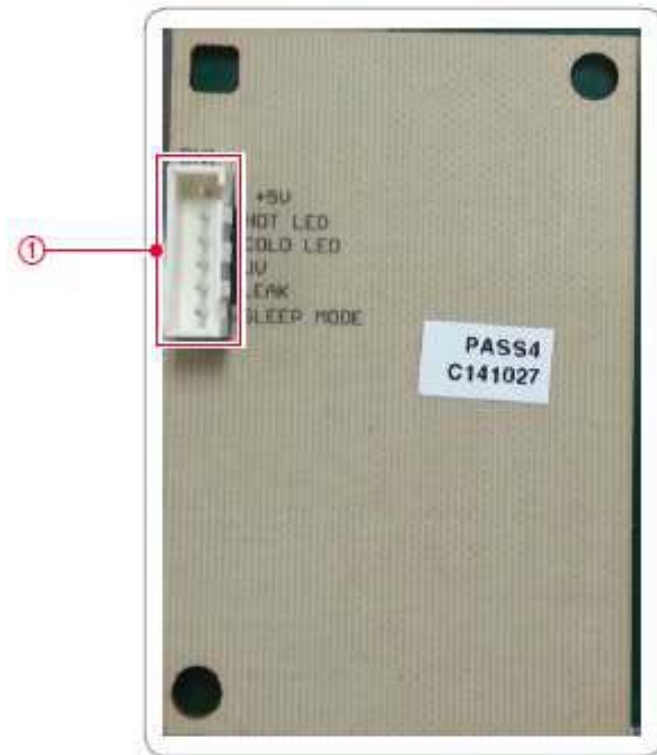

① CN1
FRONT - MAIN PBA

Pin No.	Signal
1	5 V
2	HOT LED
3	CHILLING LED
4	UV LED
5	SERVICE LED
6	SLEEP MODE SW

FAULT CODE INDEX

1. UV LED Blinking – UV Error
2. Heating and Service LED Blink Simultaneously – Hot Water Sensor Error
3. Chilling and Service LED Light Blink Simultaneously – Cold Water Sensor Error
4. Heating and Service LED Alternate Blinking –Low Water Level Error
5. Chilling and Service LED Alternate Blinking – Full Water Level Error
6. Heating, Chilling and Service LED Sequentially Blink
7. Service LED is On – Leak Detection Probe Has Detected Water

UV LED Blinking – UV Error

Possible Reason	Solution
UV Lamp or Pump is Not Operational	Check Connections to UV Lamp / Pump Assembly. Replace UV Lamp / Pump Assembly as needed.

Heating and Service LED Blink Simultaneously – Hot Water Sensor Error

Possible Reason	Solution
Sensor not connected or is not operating within set parameters	<ol style="list-style-type: none"> 1. Check connection to Hot water sensor. 2. Check OHMS reading – above 900K indicates open sensor. Below 5.2K indicates sensor short. Replace Hot Water Sensor.

Chilling and Service LED Light Blink Simultaneously – Cold Water Sensor Error

Possible Reason	Solution
Sensor is not connected or is not operating within set parameters	<ol style="list-style-type: none"> 1. Check connection to Cold Water Sensor. 2. Check OHMS reading – above 690K Indicates Open Sensor, below 7.3K indicates Sensor Short. Replace Cold Water Sensor.

Heating and Service LED Alternate Blinking –Low Water Level Error

Possible Reason	Solution
Full level sensor has detected water, but low level is not detected	Check connection to low water level sensor. Replace low water level sensor.

Chilling and Service LED Alternate Blinking – Full Water Level Error

Possible Reason	Solution
Low Level and Overflow Sensors indicted water but full level sensor is not detected	Check connection to low water level sensor. Replace full water level sensor.

Heating, Chilling and Service LED Sequentially Blink

Possible Reason	Solution
Overflow sensor has detected water but neither low or full sensors are detected	Check connections to both low and full water sensors. Replace both Low Water and Full Water Sensors.

Heating, Chilling and Service LED Blinks Simultaneously

Possible Reason	Solution
All three level sensors have detected water	Check Feed Valve for Debris. Clean or replace feed valve.

Service LED is On – Leak Detection Probe Has Detected Water

Possible Reason	Solution
Dry inside of unit and leak detector.	Check unit for leak and repair or replace faulty parts.

COLD WATER TROUBLESHOOTING

COLD WATER MALFUNCTION

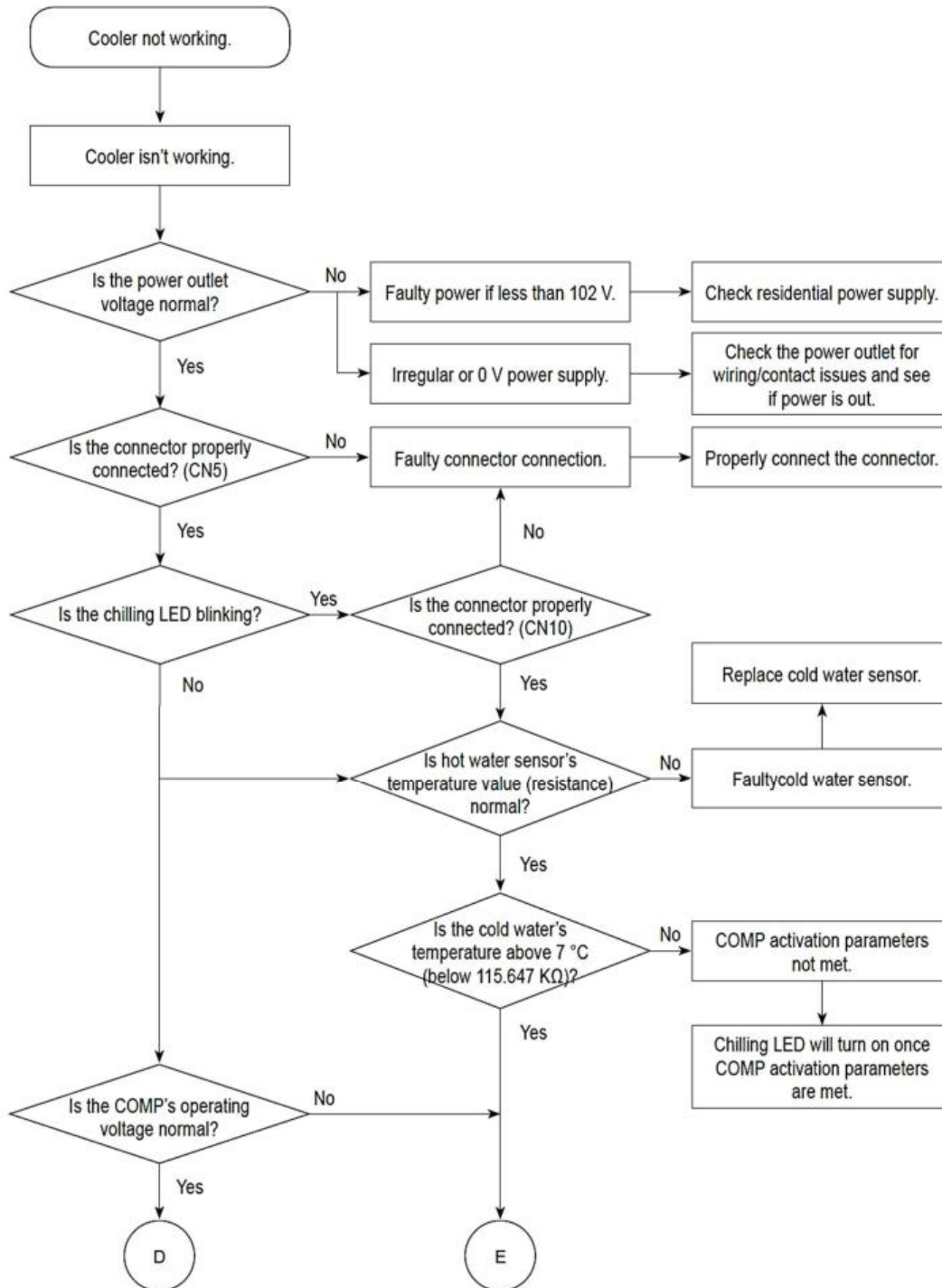

COLD WATER MALFUNCTION continued

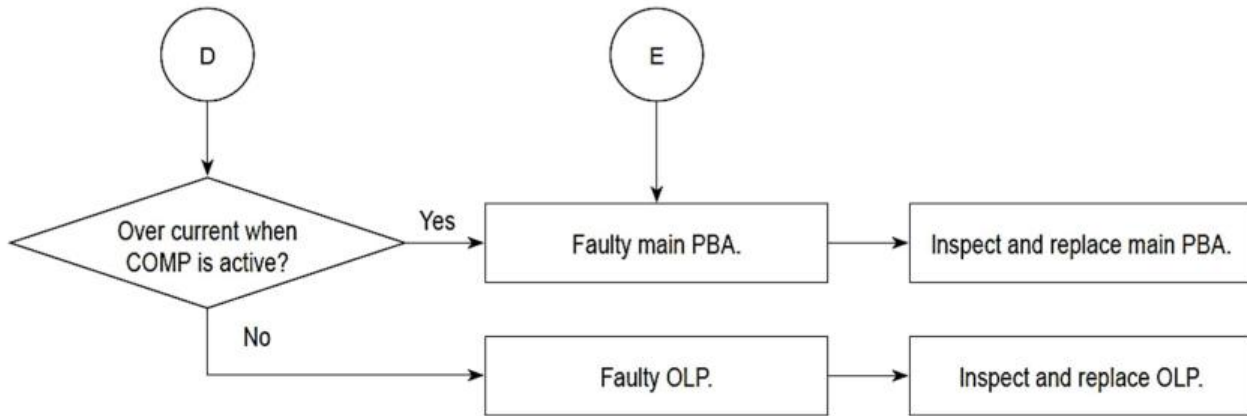

HOT WATER TROUBLESHOOTING

HOT WATER MALFUNCTION

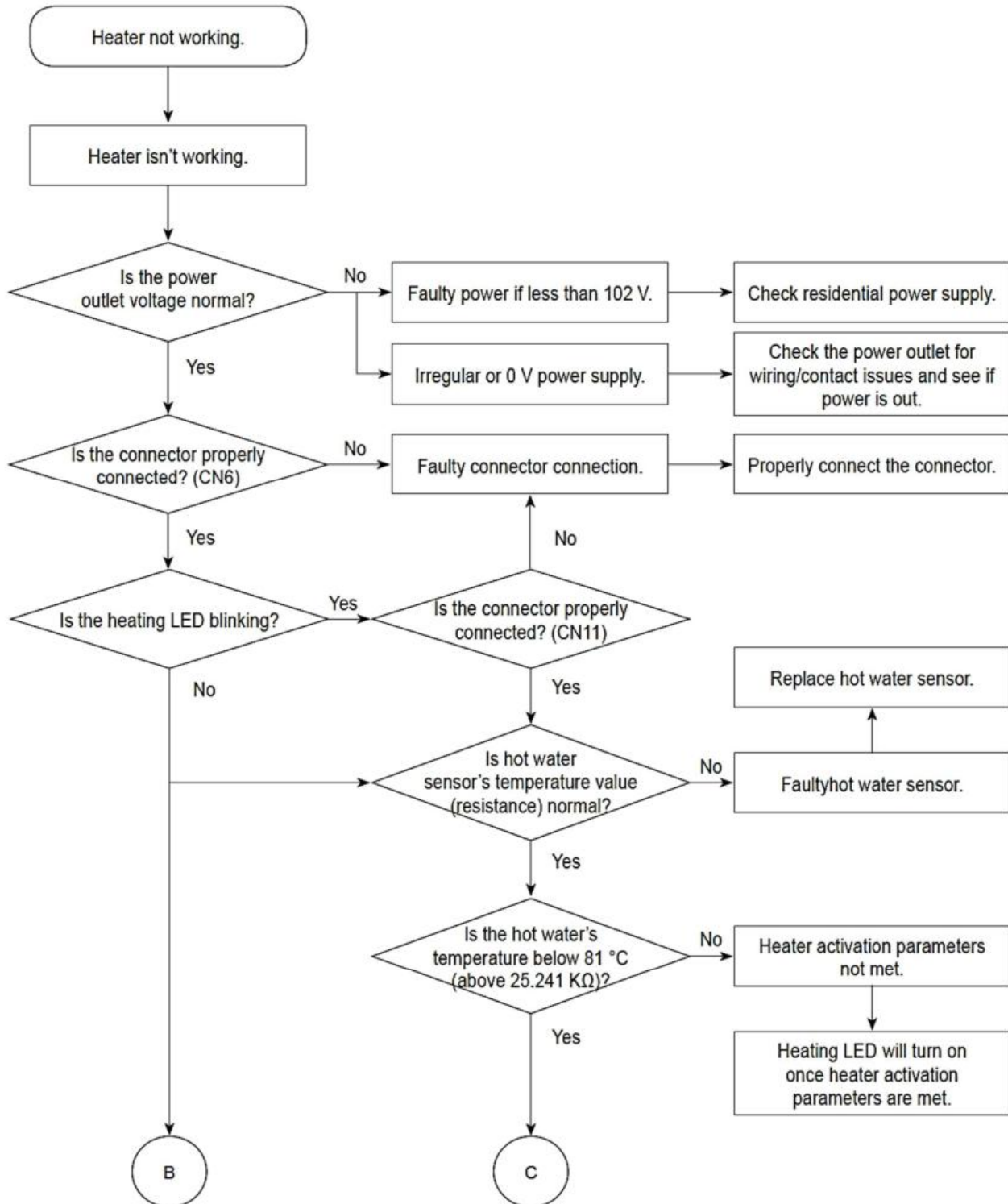

HOT WATER MALFUNCTION continued

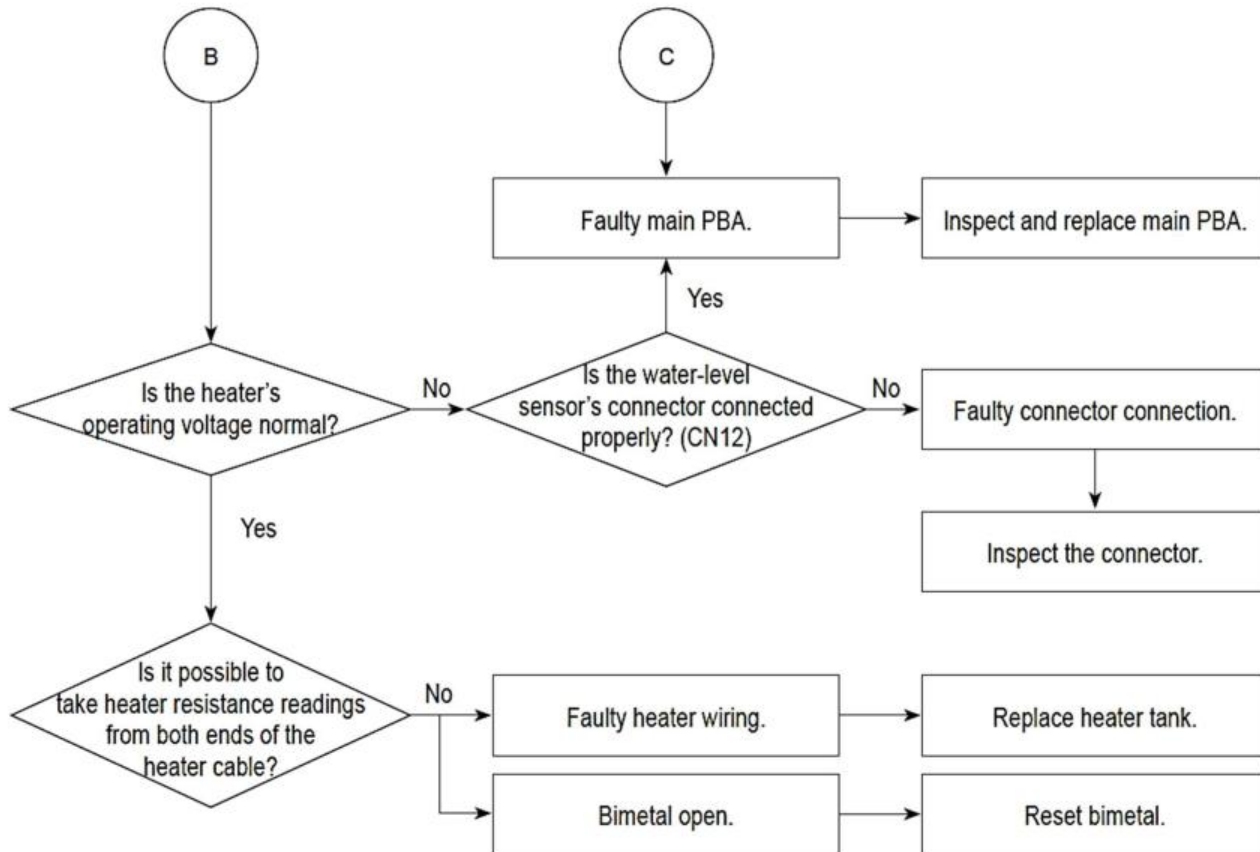

POWER TROUBLESHOOTING

POWER SUPPLY FAULT

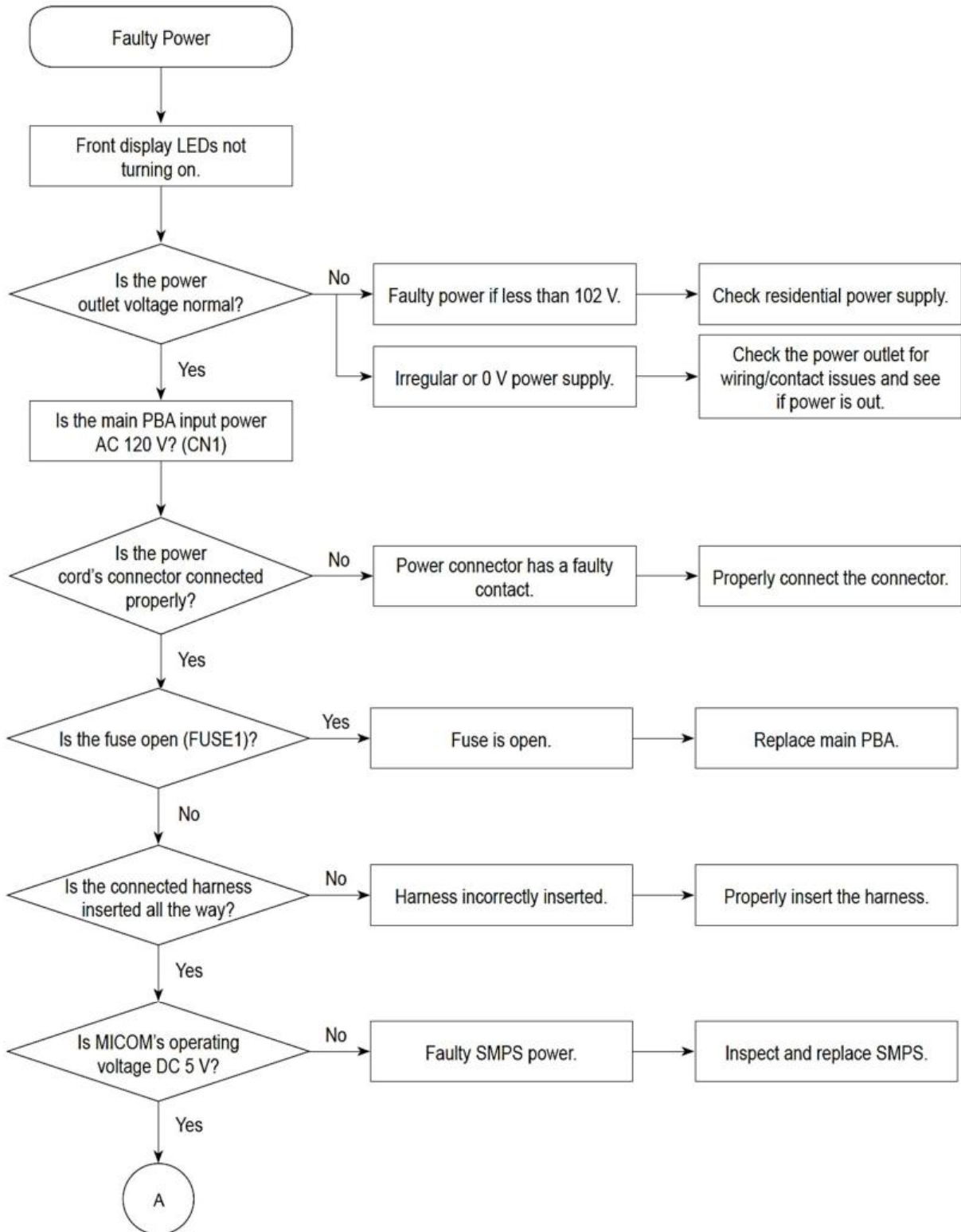

POWER SUPPLY FAULT - continued

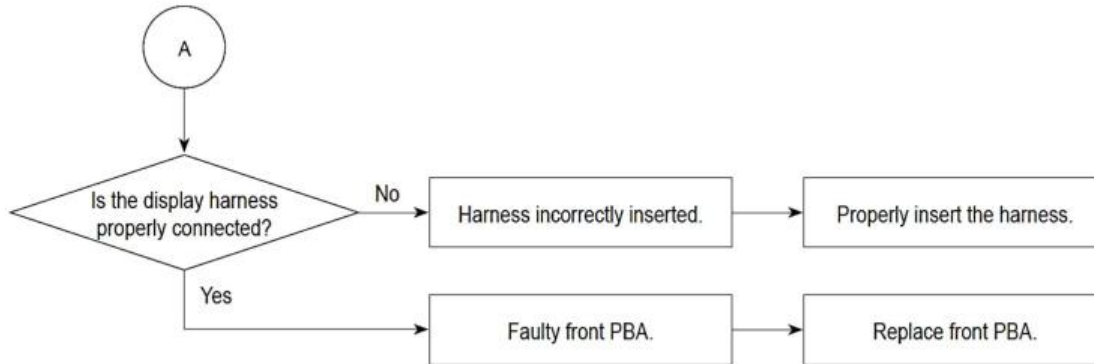

DISPENSE TROUBLESHOOTING

DISPENSING MALFUNCTION

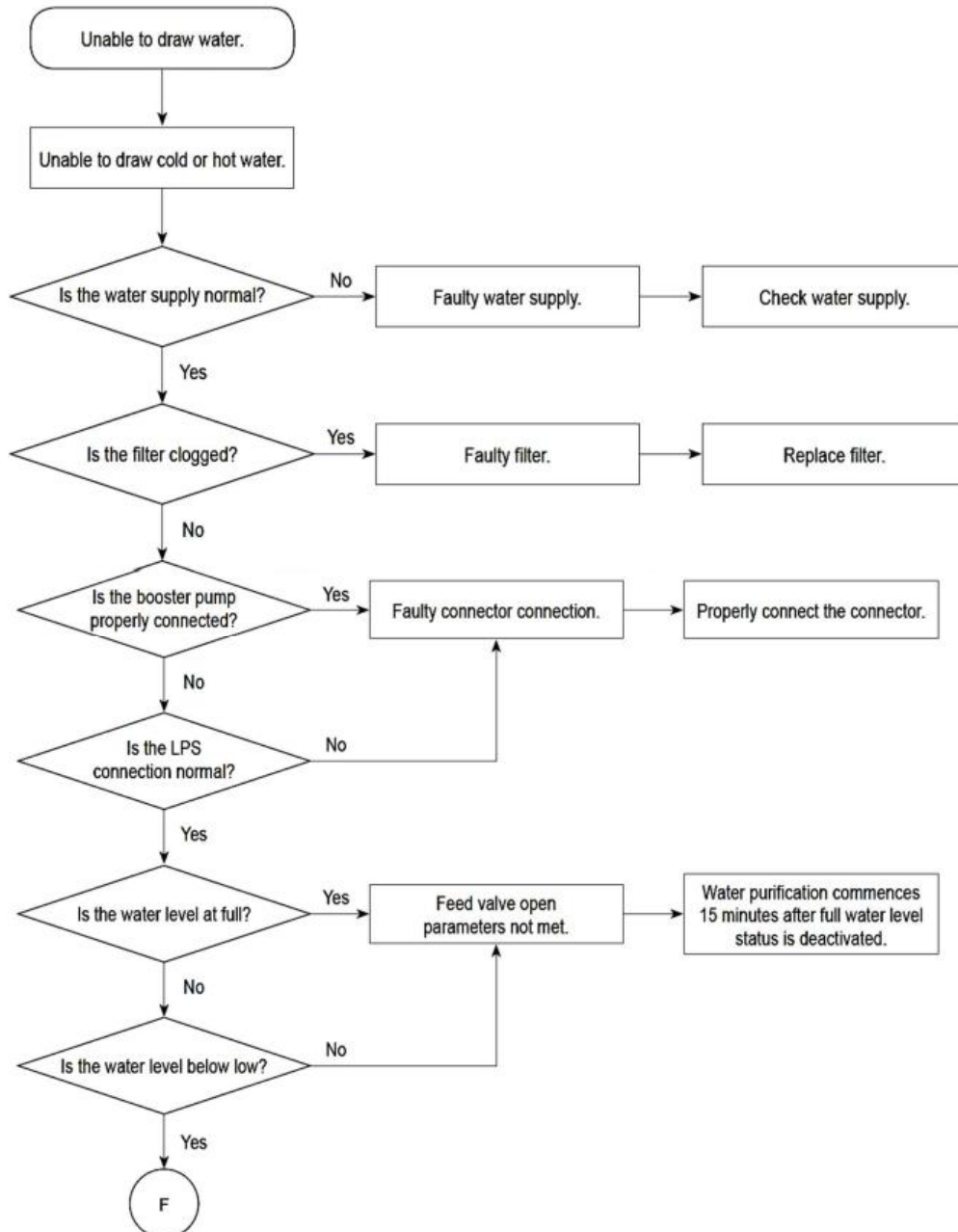

TROUBLESHOOTING

DISPENSING MALFUNCTION continued

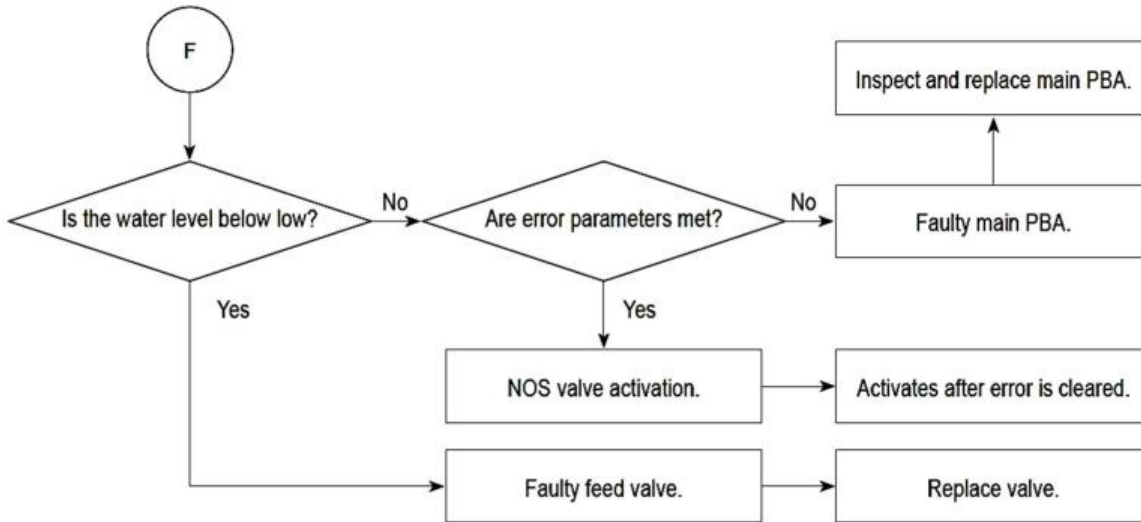

UV MODULE TROUBLESHOOTING

UV MODULE MALFUNCTION

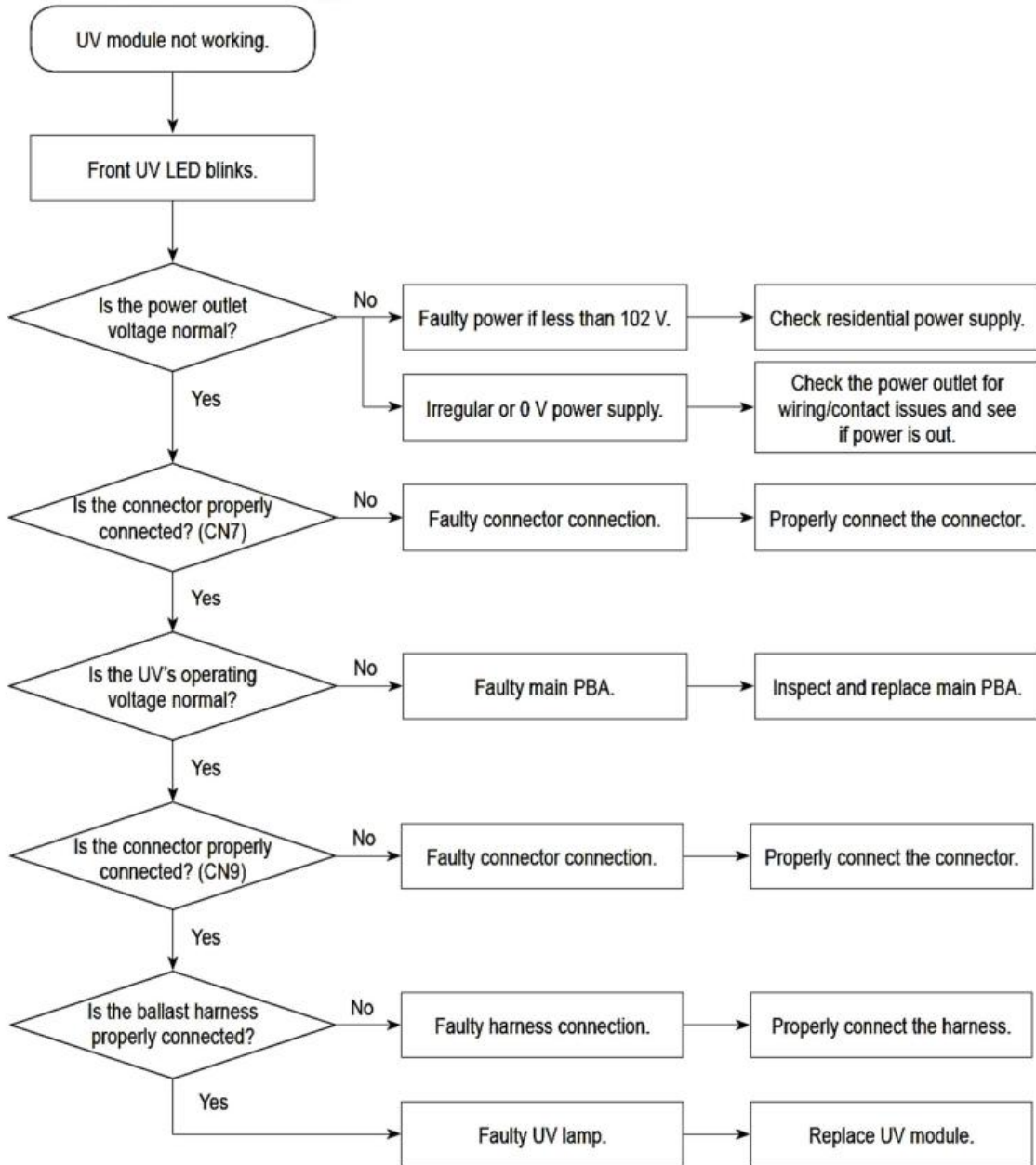



WATERLOGIC MANUFACTURED WATER TREATMENT SYSTEM LIMITED WARRANTY **UNITED STATES AND CANADA ONLY**

Waterlogic water treatment systems are guaranteed to the original purchaser to be free of defects in materials and workmanship for a period of one (1) year from the date of purchase. Waterlogic Commercial Products, LLC (“Waterlogic”) based in the U.S.A. and its affiliated companies are not liable for any cost of removal, installation, transportation, or any other charges which may arise in connection with a warranty claim.

This warranty does not cover damage or wear to products caused by abnormal operating conditions, accident, abuse, misuse, unauthorized or improper alteration or repair, damage caused by or resulting from shipping or accident, damage caused by hot water, freezing, flood, fire, or acts of God. The effects from chlorine corrosion, scaling and normal wear are specifically excluded from this warranty. This warranty does not cover products used outside the countries where the unit was purchased, and does not cover products that were not installed in accordance with Waterlogic printed installation and operating instructions obtained in training or from www.waterlogic.us. Failure to follow all instructions for operation and maintenance voids the warranty. This warranty is not transferable.

To obtain warranty repairs or replacement, you must obtain a Return Authorization from Waterlogic. To obtain a Return Authorization, you must submit a Return Authorization form with supporting documentation to Waterlogic for evaluation. The form is available at www.waterlogic.us. Supporting documentation must include, but is not limited to; proof of purchase, installation date, failure date, and supporting installation and maintenance data. After you submit a Return Authorization form and supporting documentation, Waterlogic will determine whether a reasonably apparent defect in materials or workmanship covered by this limited warranty exists. If Waterlogic determines the claimed defect is covered by this warranty, Waterlogic will, at its sole discretion, determine whether to correct the defect or replace the unit, free of charge to you. If Waterlogic determines that the unit should be returned for warranty service, Waterlogic will approve of return in writing and will issue a Return Authorization which you must obtain prior to shipping the product. You are responsible for the cost of freight in to Waterlogic.

Waterlogic and its affiliated companies hereby limit the duration of any and all implied warranties to a maximum period of one (1) year from the date of purchase including, but not limited to, the implied warranties of merchantability and fitness for a particular purpose. Some states do not allow limitations on how long an implied warranty lasts, so the above limitation may not apply to you. Consequential and incidental damages are not recoverable under this warranty. Some states do not allow the exclusion or limitation of incidental or consequential damages, so the above limitation or exclusion may not apply to you.

This warranty gives you specific legal rights and you may also have other rights which may vary from state to state.

New Warranty Policy issued by Waterlogic Commercial Products LLC, USA - January 10, 2014

Waterlogic Commercials Products LLC
3175 Bass Pro Drive
Grapevine, TX 76051

Tel: (800) 288-1891
Website: waterlogic.us